

LINEA DEL TAGLIO



PROGETTO CON ABBONDAGGIO



LINEA DI SICUREZZA (tutti gli elementi importanti devono essere inseriti all'interno di questa linea)

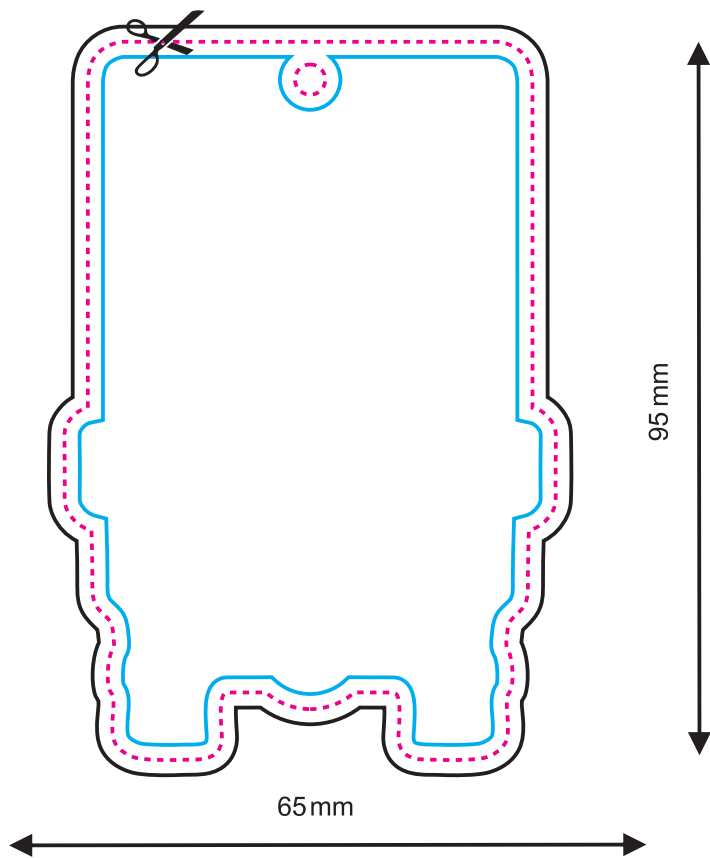

Fronte

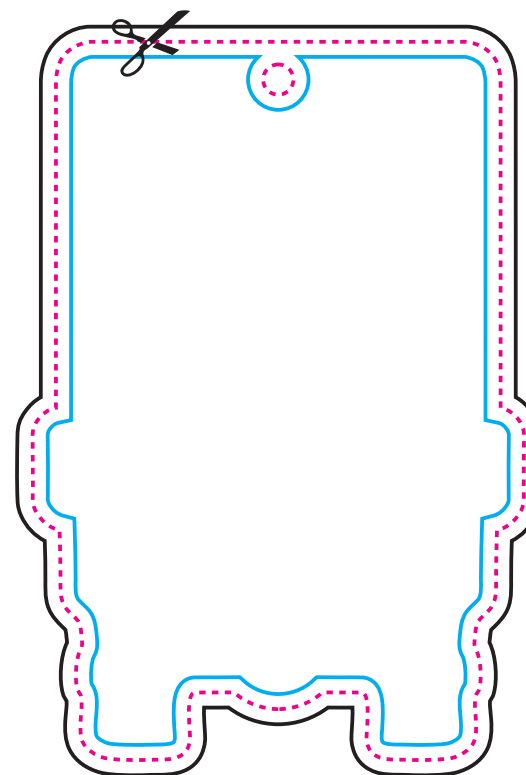

Retro

LINEA DEL TAGLIO



PROGETTO CON ABBONDAGGIO



LINEA DI SICUREZZA (tutti gli elementi importanti devono essere inseriti all'interno di questa linea)

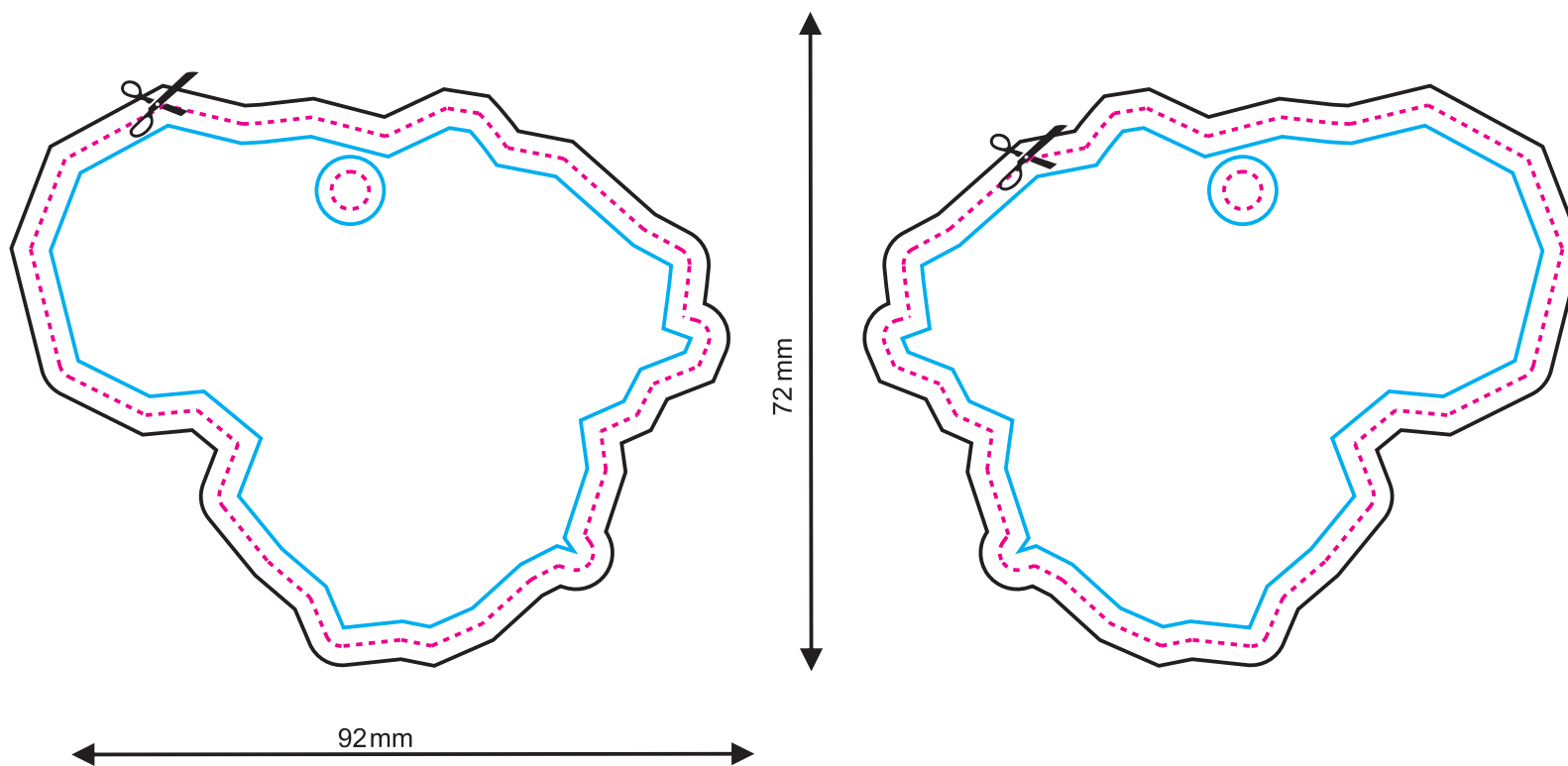

Fronte

Retro

LINEA DEL TAGLIO



PROGETTO CON ABBONDAGGIO



LINEA DI SICUREZZA (tutti gli elementi importanti devono essere inseriti all'interno di questa linea)

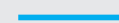

Fronte

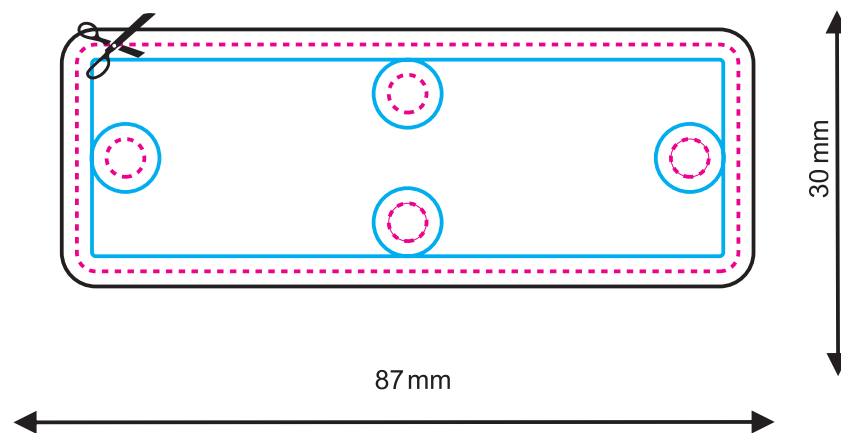

Retro

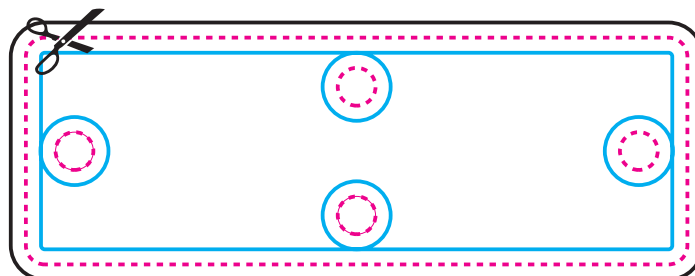

LINEA DEL TAGLIO



PROGETTO CON ABBONDAGGIO



LINEA DI SICUREZZA (tutti gli elementi importanti devono essere inseriti all'interno di questa linea)

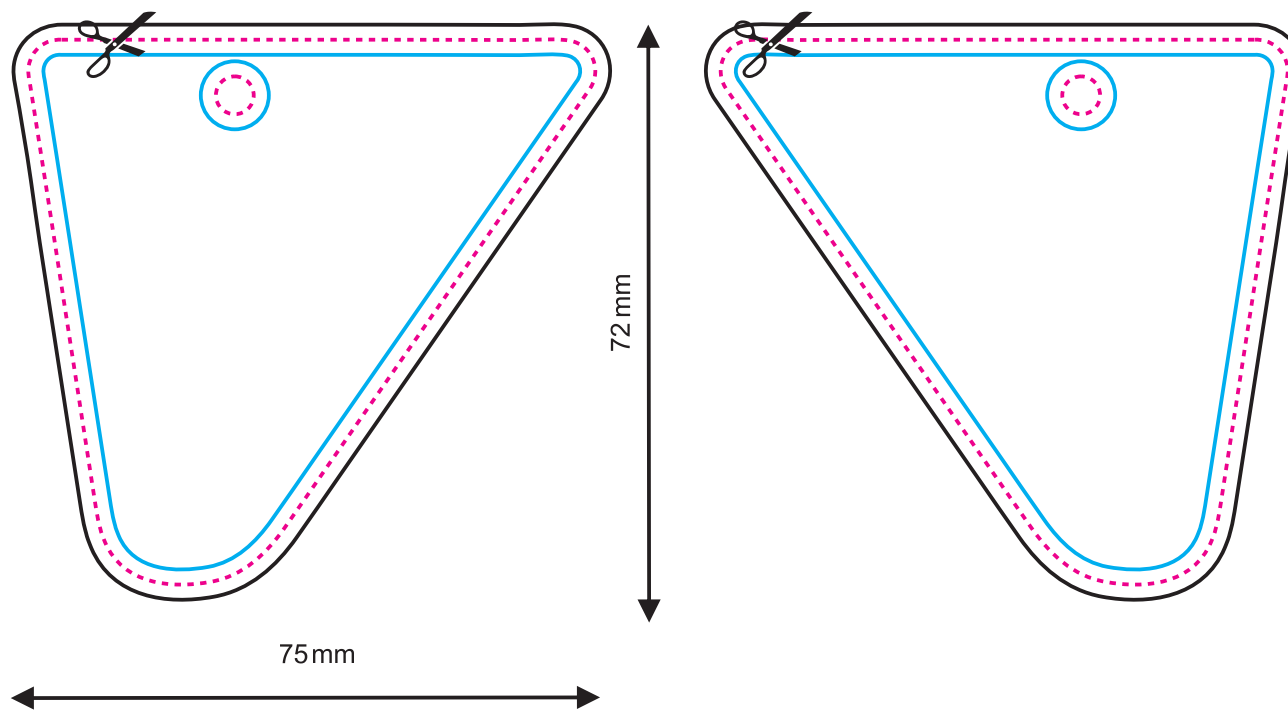
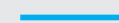

Fronte

Retro

LINEA DEL TAGLIO



PROGETTO CON ABBONDAGGIO

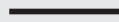

LINEA DI SICUREZZA (tutti gli elementi importanti devono essere inseriti all'interno di questa linea)

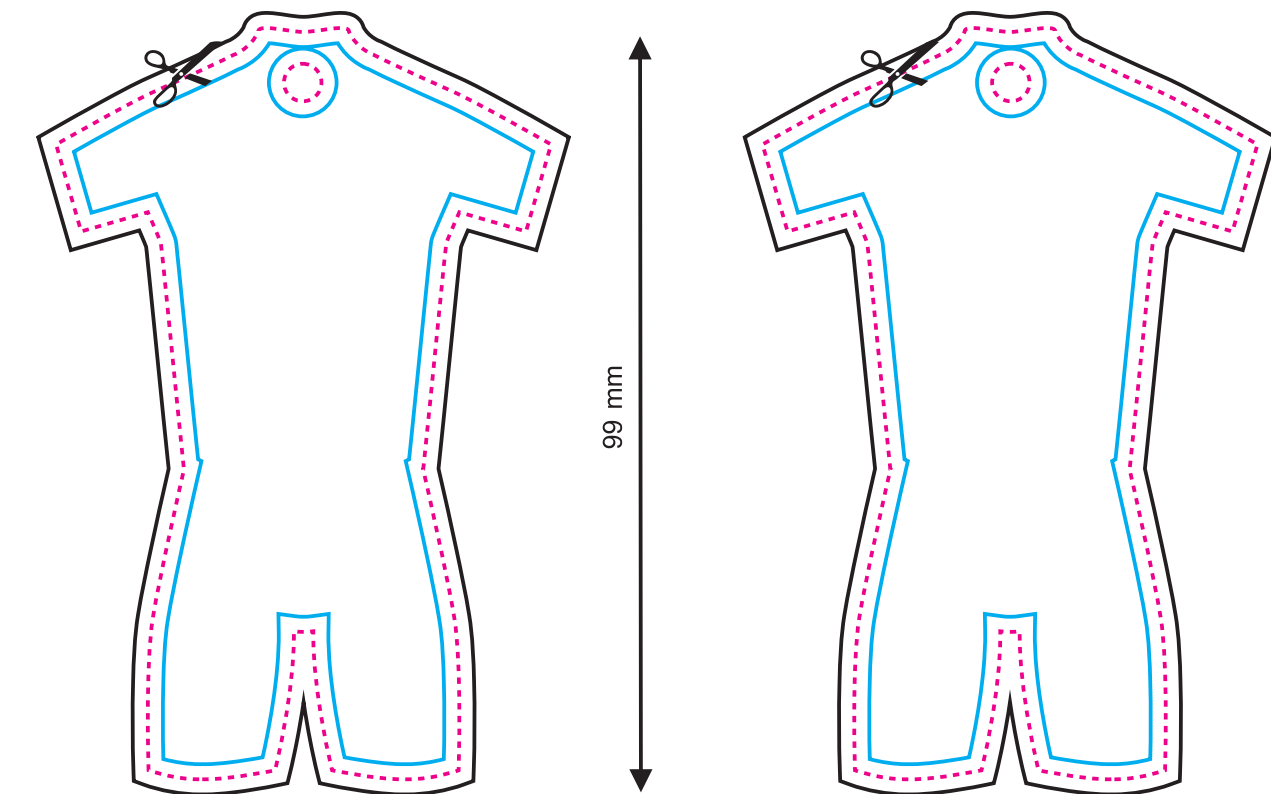

Fronte

Retro

607

LEGENDA

LINEA DEL TAGLIO



PROGETTO CON ABBONDAGGIO

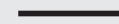

LINEA DI SICUREZZA (tutti gli elementi importanti devono essere inseriti all'interno di questa linea)

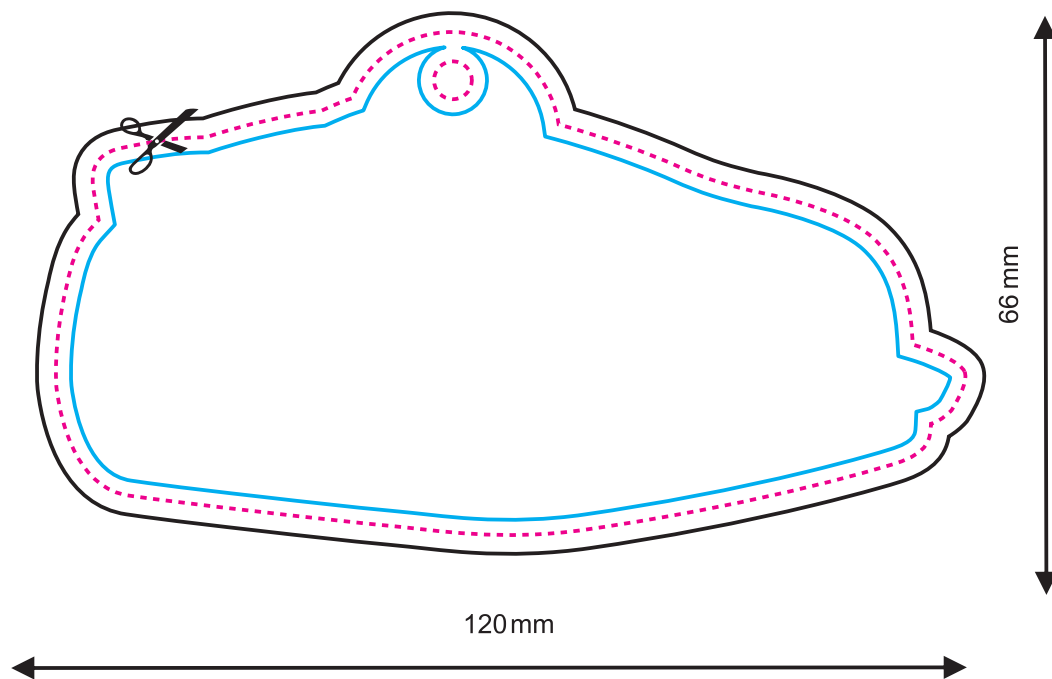

Fronte

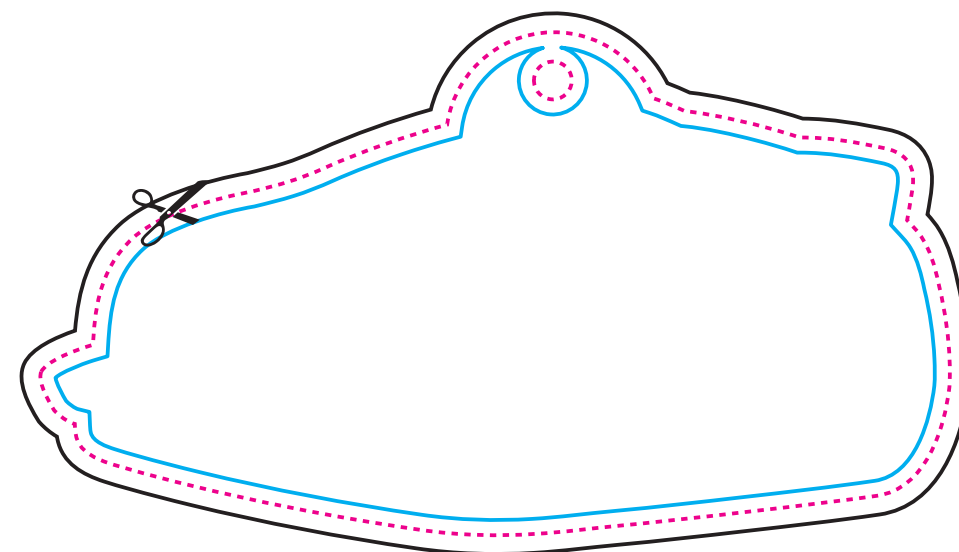

Retro

LINEA DEL TAGLIO



PROGETTO CON ABBONDAGGIO

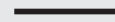

LINEA DI SICUREZZA (tutti gli elementi importanti devono essere inseriti all'interno di questa linea)

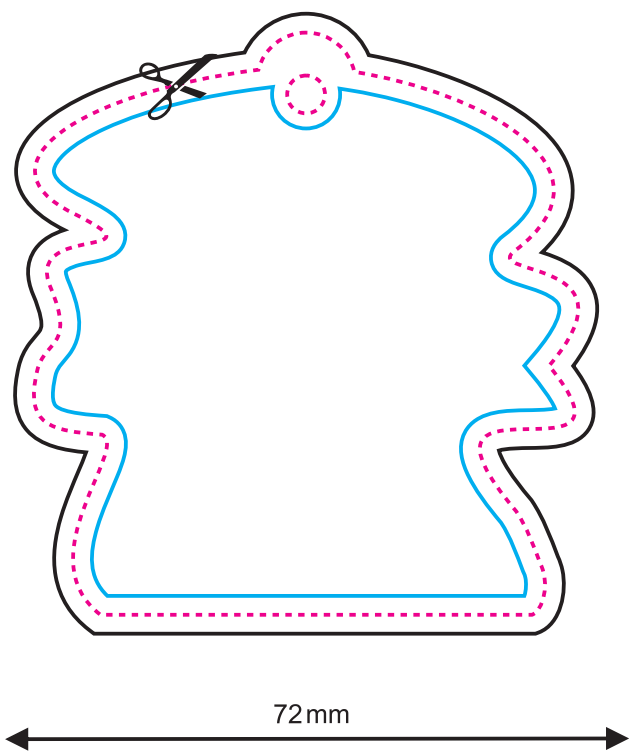

Fronte

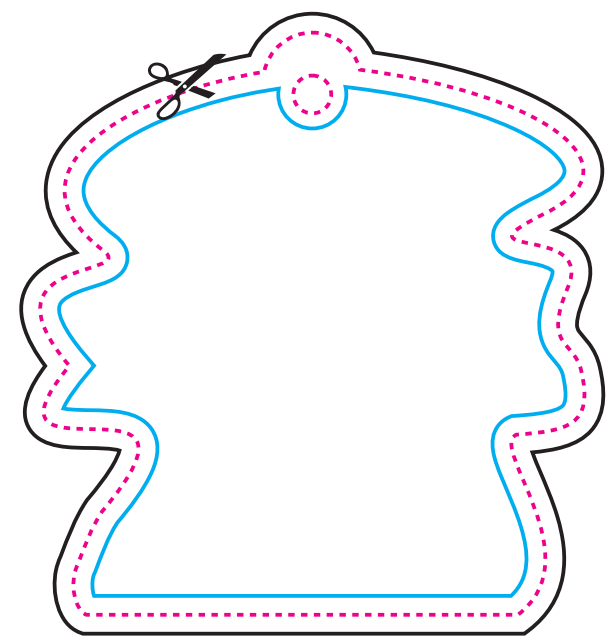

Retro

LINEA DEL TAGLIO



PROGETTO CON ABBONDAGGIO



LINEA DI SICUREZZA (tutti gli elementi importanti devono essere inseriti all'interno di questa linea)

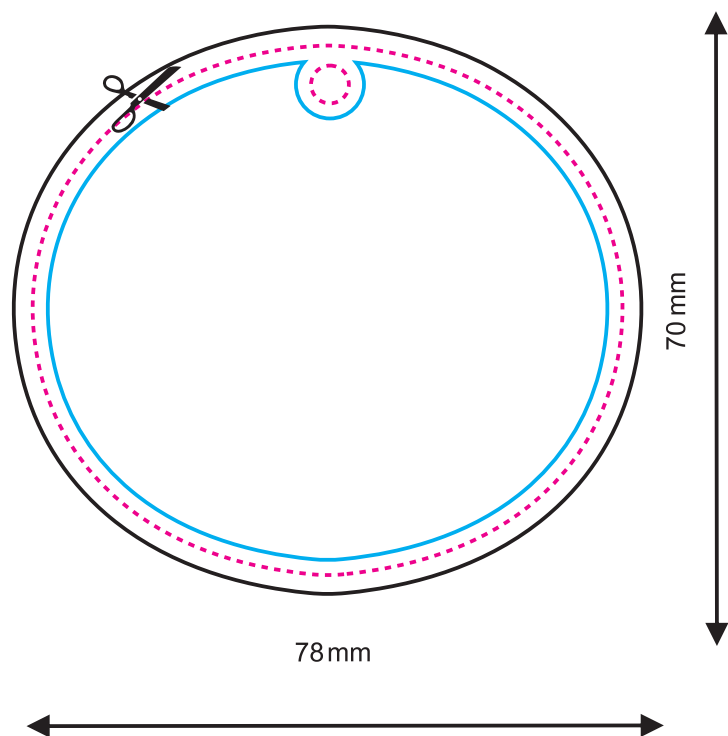

Fronte

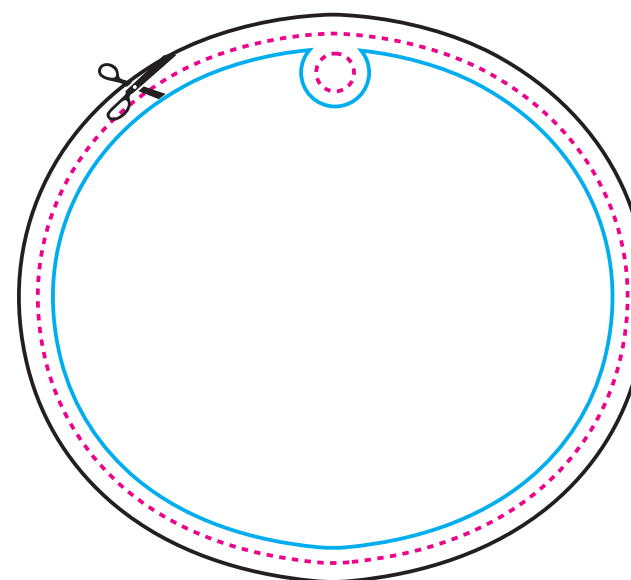

Retro



609

LEGENDA

LINEA DEL TAGLIO



PROGETTO CON ABBONDAGGIO

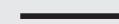

LINEA DI SICUREZZA (tutti gli elementi importanti devono essere inseriti all'interno di questa linea)

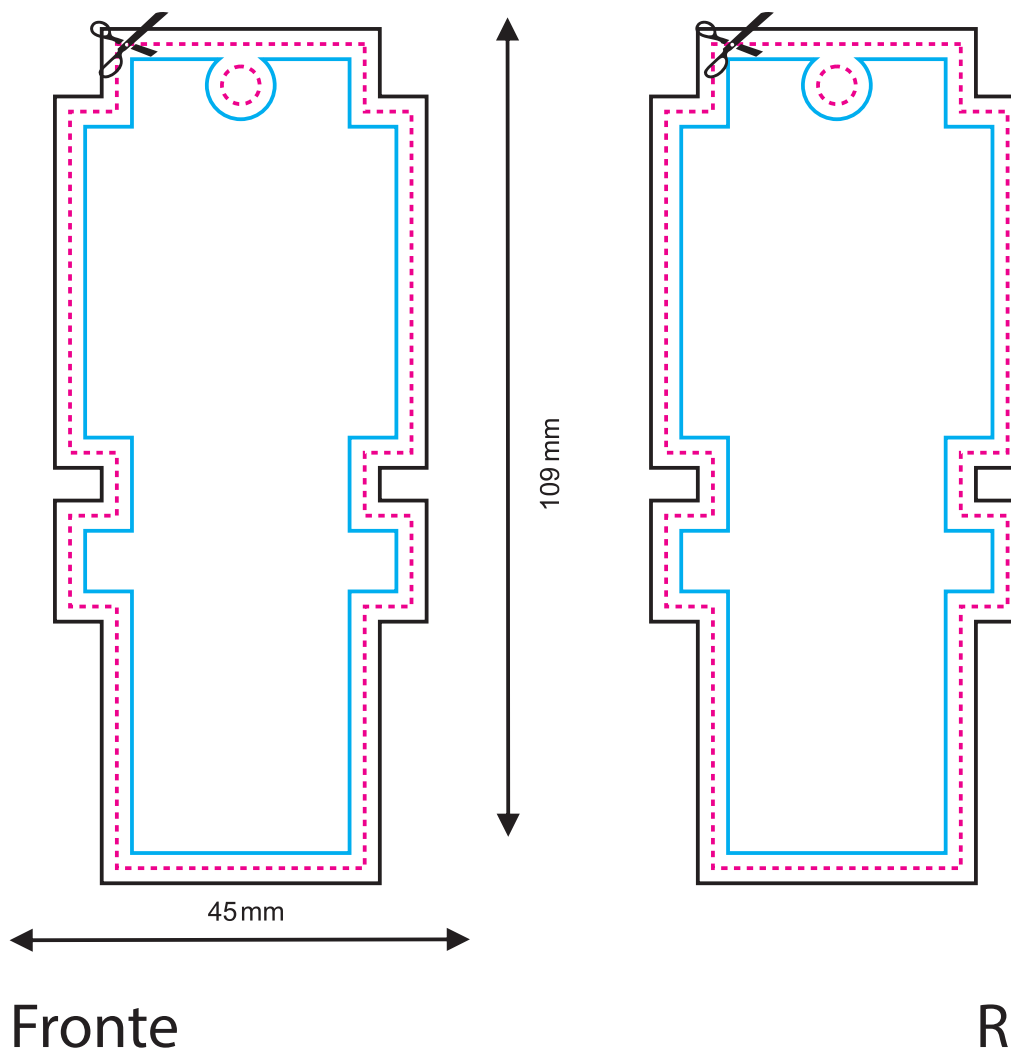
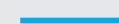

610

LEGENDA

LINEA DEL TAGLIO



PROGETTO CON ABBONDAGGIO



LINEA DI SICUREZZA (tutti gli elementi importanti devono essere inseriti all'interno di questa linea)

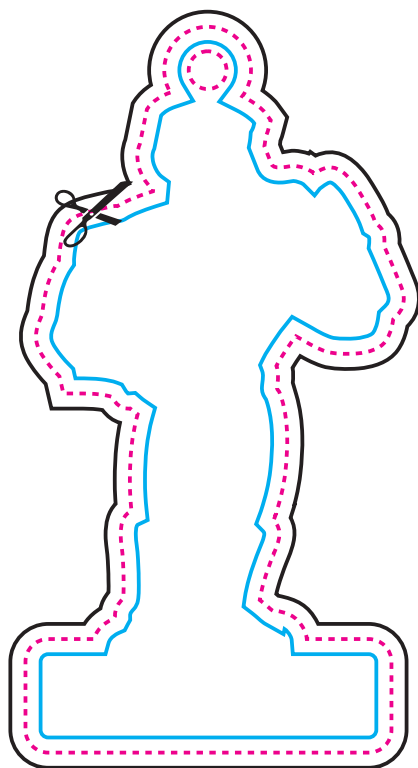

96 mm

50 mm

Fronte

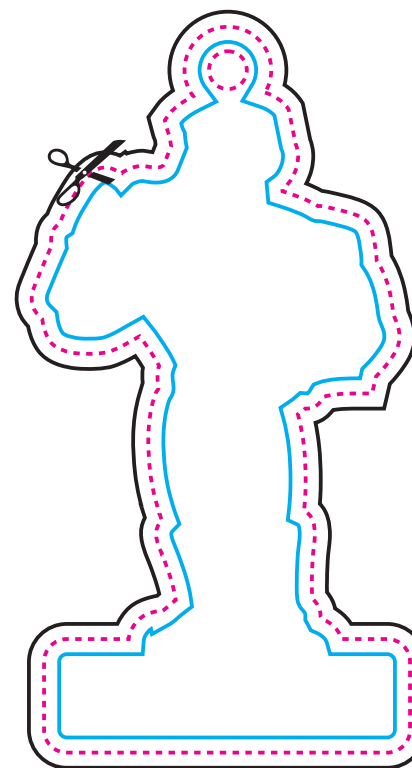

Retro

LINEA DEL TAGLIO



PROGETTO CON ABBONDAGGIO

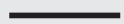

LINEA DI SICUREZZA (tutti gli elementi importanti devono essere inseriti all'interno di questa linea)

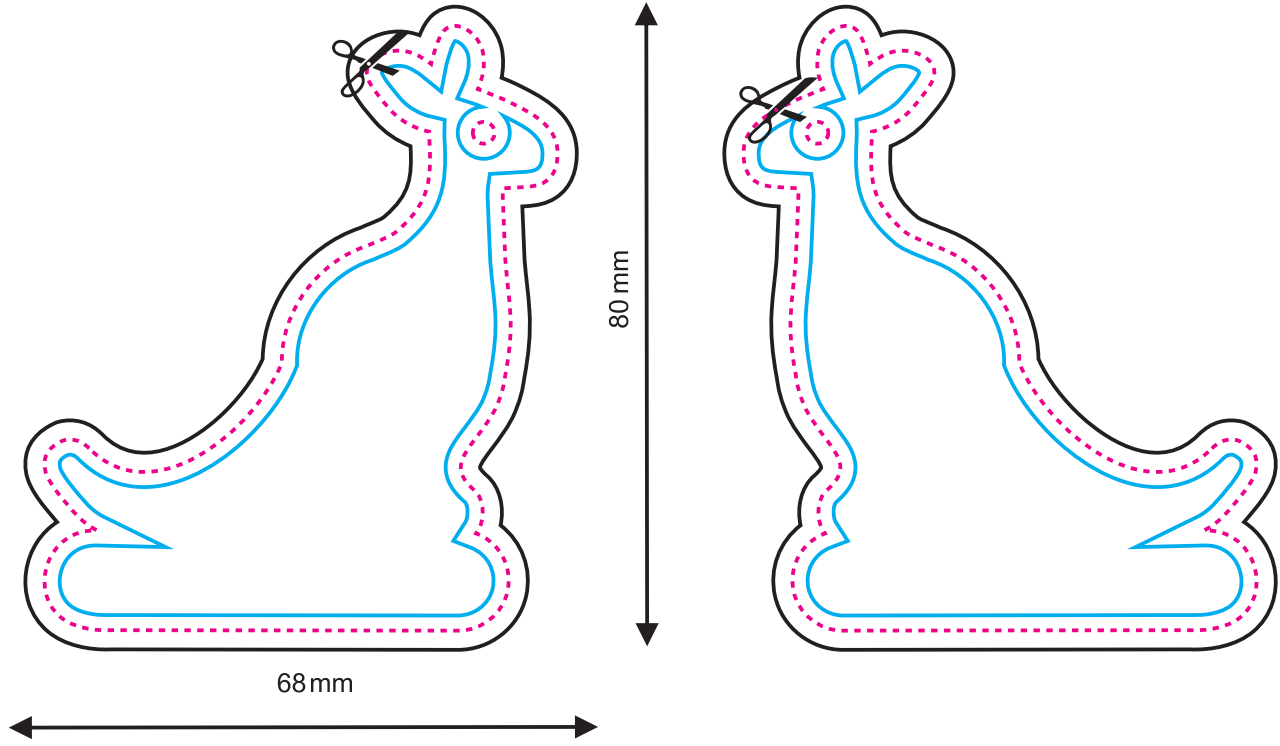

Fronte

Retro

LINEA DEL TAGLIO



PROGETTO CON ABBONDAGGIO



LINEA DI SICUREZZA (tutti gli elementi importanti devono essere inseriti all'interno di questa linea)

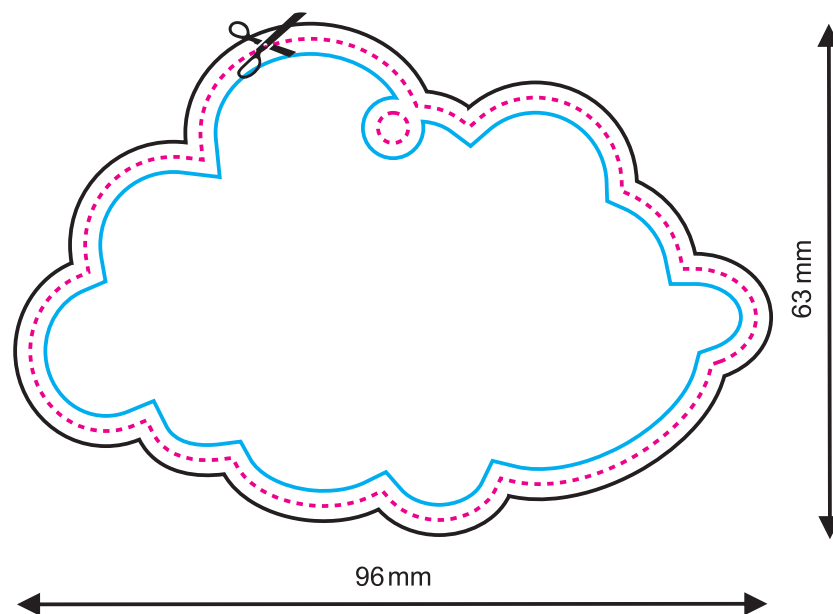
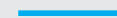

Fronte

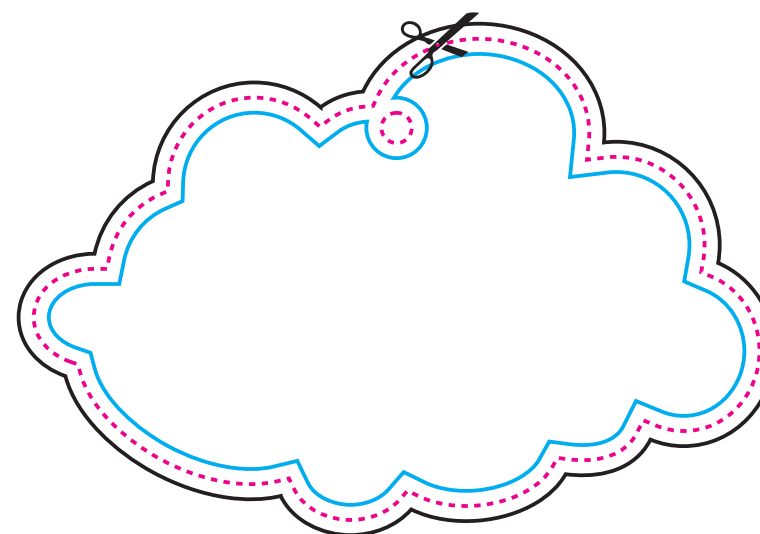

Retro

613

LEGENDA

LINEA DEL TAGLIO



PROGETTO CON ABBONDAGGIO



LINEA DI SICUREZZA (tutti gli elementi importanti devono essere inseriti all'interno di questa linea)

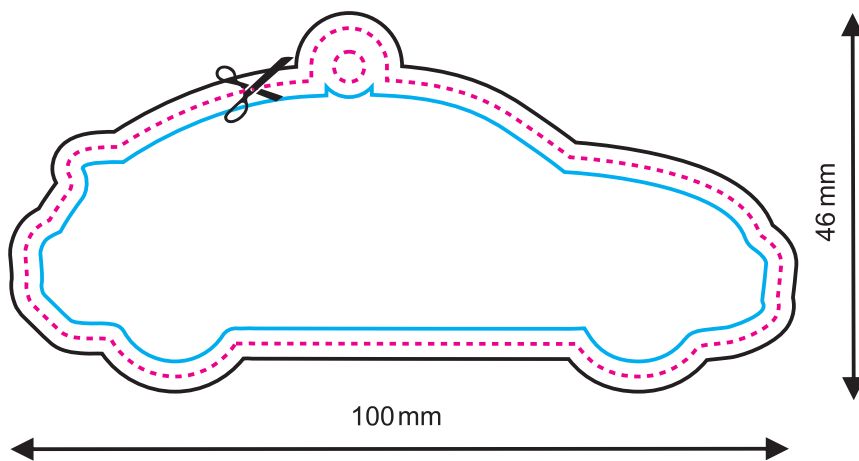

Fronte

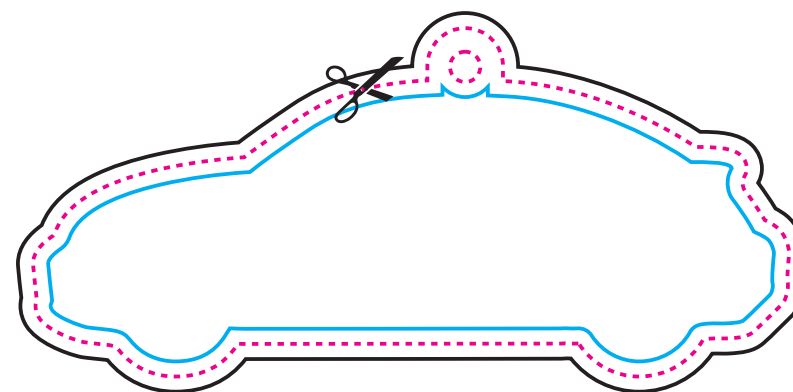

Retro

LINEA DEL TAGLIO



PROGETTO CON ABBONDAGGIO

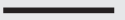

LINEA DI SICUREZZA (tutti gli elementi importanti devono essere inseriti all'interno di questa linea)

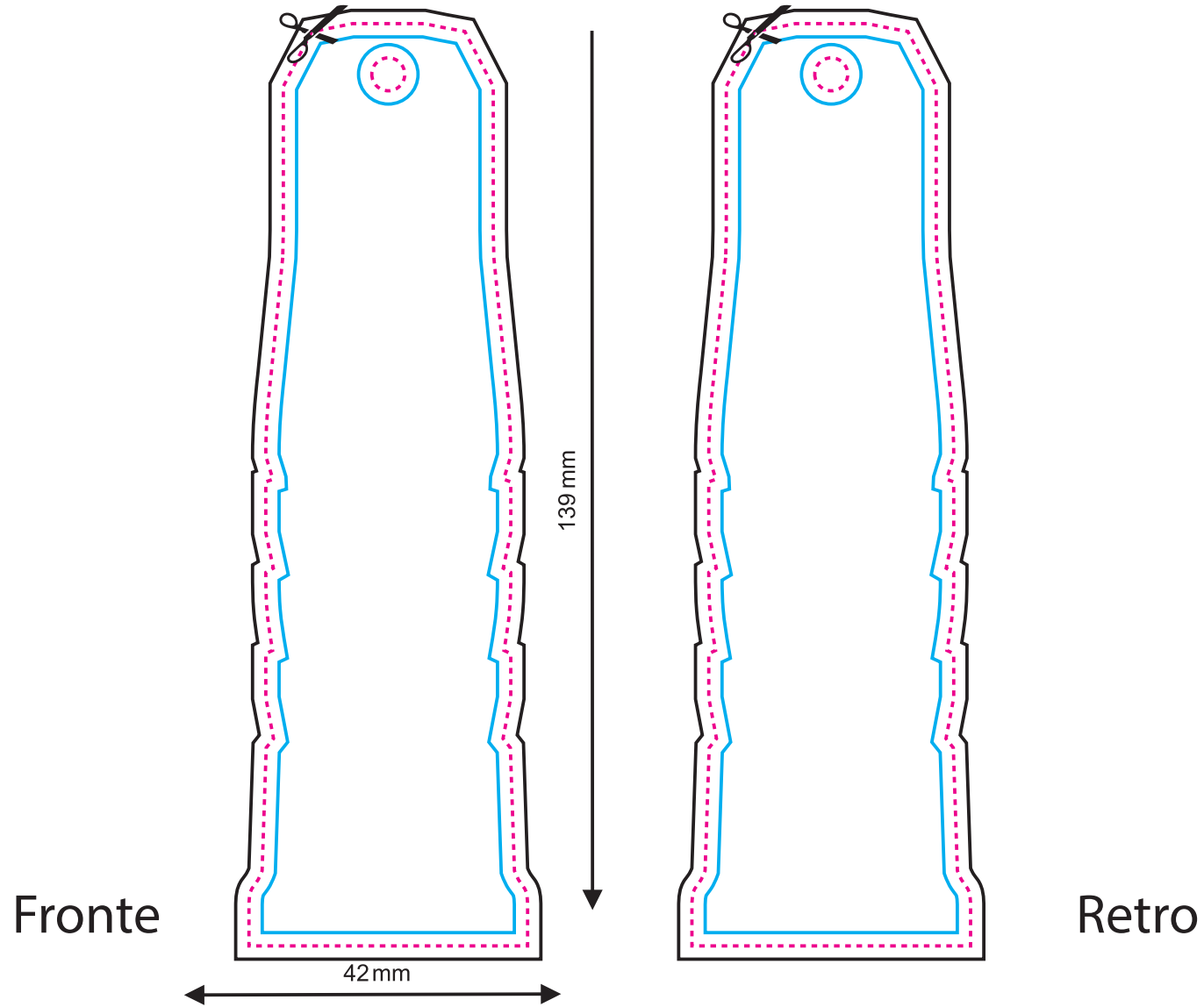
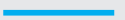

LINEA DEL TAGLIO



PROGETTO CON ABBONDAGGIO

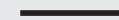

LINEA DI SICUREZZA (tutti gli elementi importanti devono essere inseriti all'interno di questa linea)

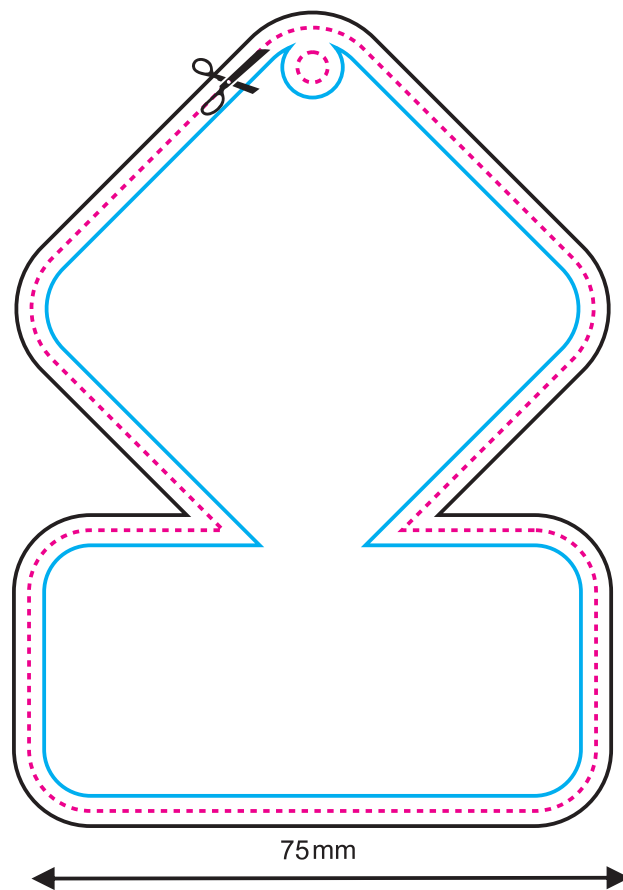
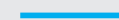

Fronte

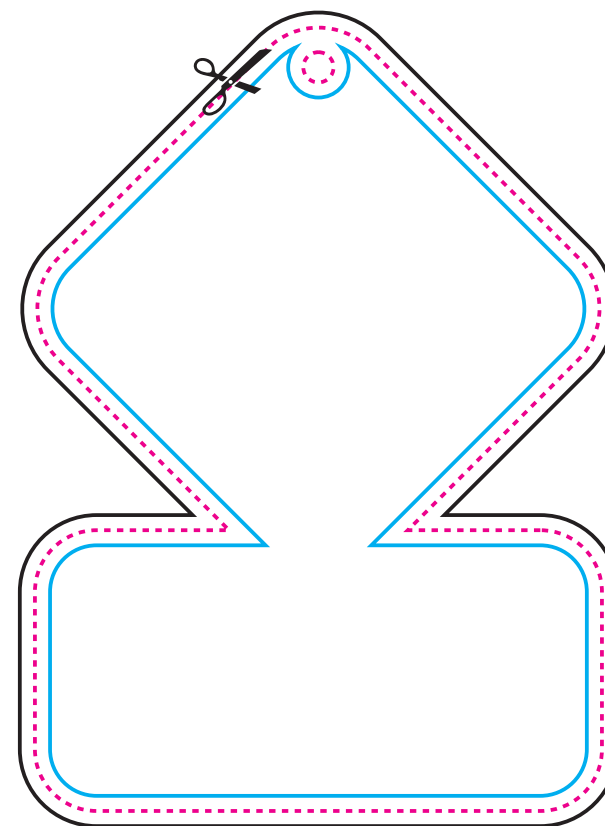

Retro

LINEA DEL TAGLIO

PROGETTO CON ABBONDAGGIO

LINEA DI SICUREZZA (tutti gli elementi importanti devono essere inseriti all'interno di questa linea)

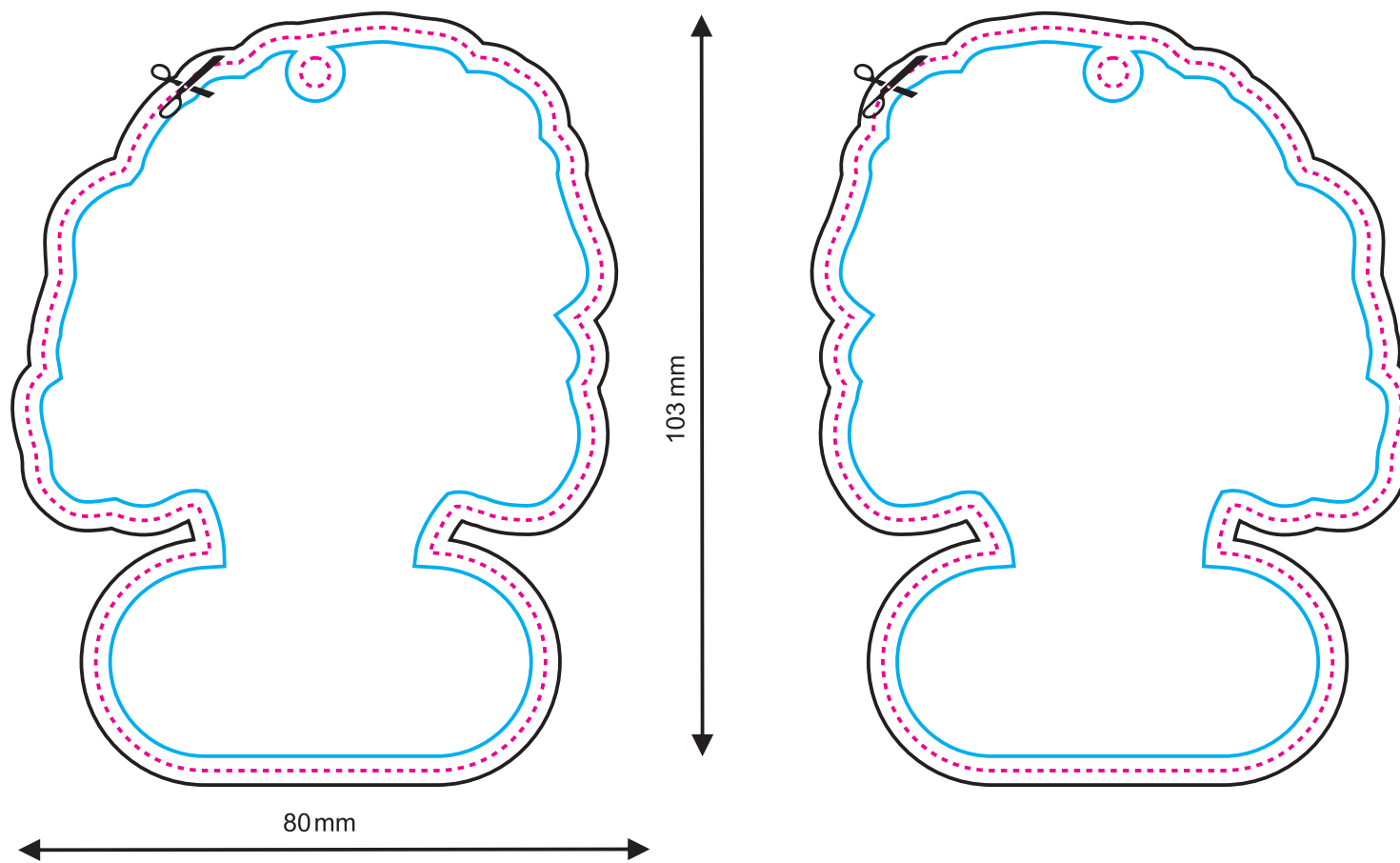

Fronte

Retro



LINEA DEL TAGLIO



PROGETTO CON ABBONDAGGIO

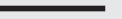

LINEA DI SICUREZZA (tutti gli elementi importanti devono essere inseriti all'interno di questa linea)

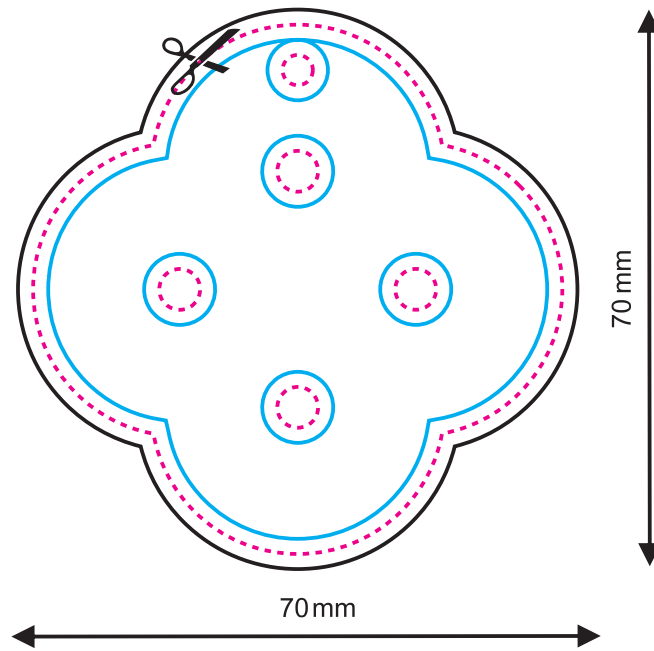

Fronte

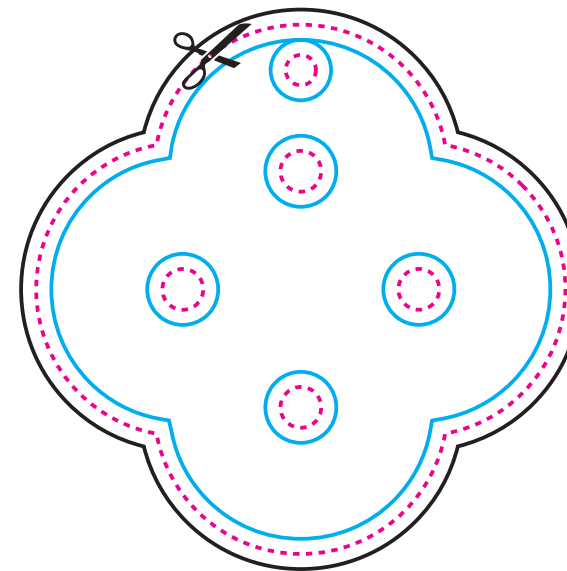

Retro

LINEA DEL TAGLIO



PROGETTO CON ABBONDAGGIO



LINEA DI SICUREZZA (tutti gli elementi importanti devono essere inseriti all'interno di questa linea)

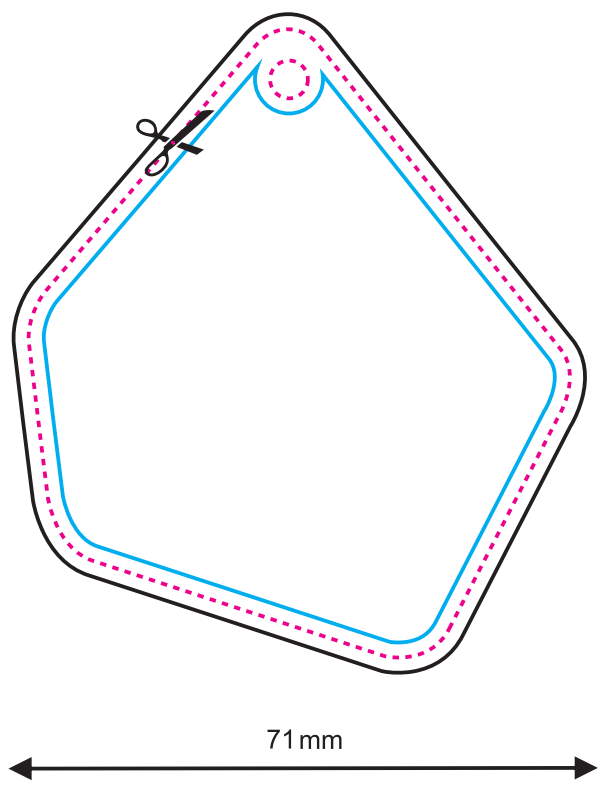
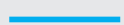

Fronte

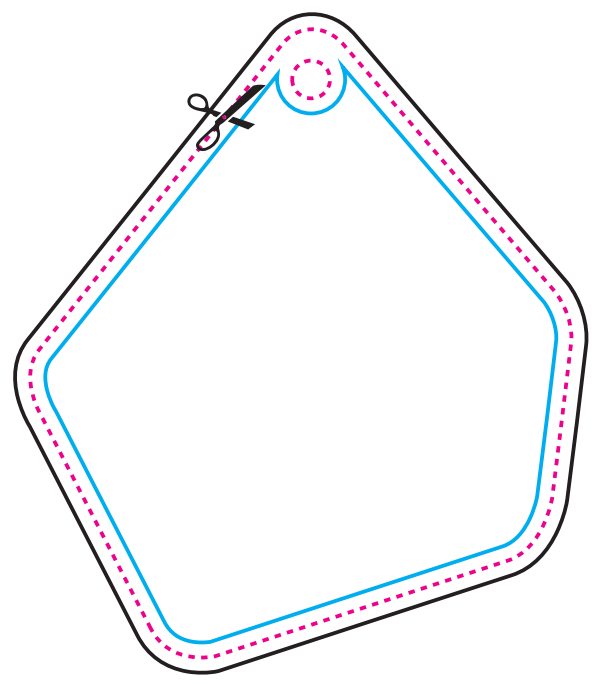

Retro

LINEA DEL TAGLIO



PROGETTO CON ABBONDAGGIO

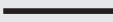

LINEA DI SICUREZZA (tutti gli elementi importanti devono essere inseriti all'interno di questa linea)

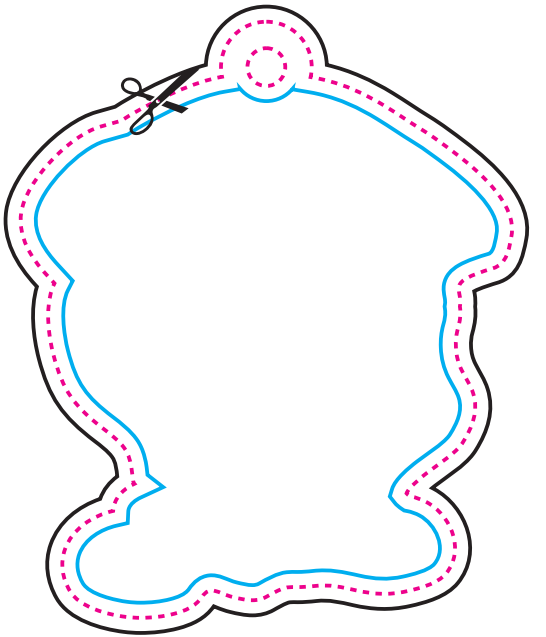
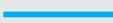

65mm

79mm

Fronte

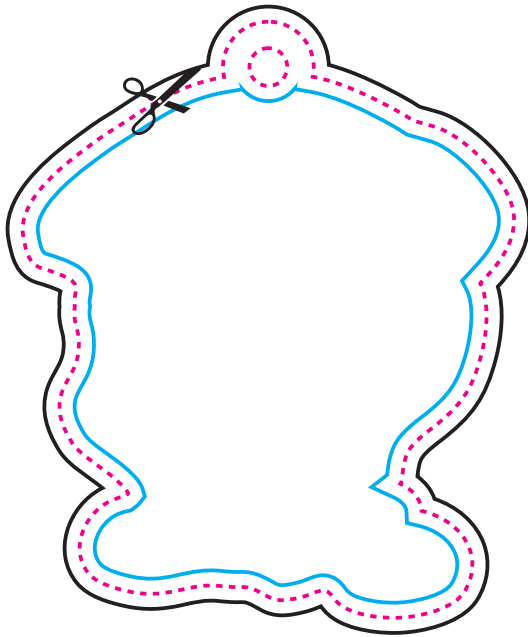

Retro

LINEA DEL TAGLIO



PROGETTO CON ABBONDAGGIO

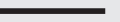

LINEA DI SICUREZZA (tutti gli elementi importanti devono essere inseriti all'interno di questa linea)

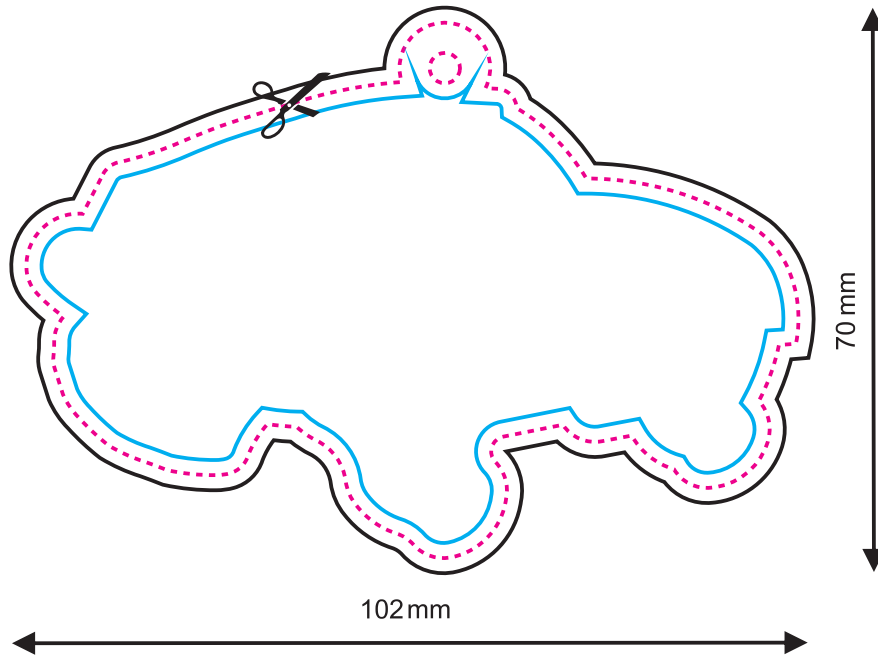
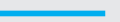

Fronte

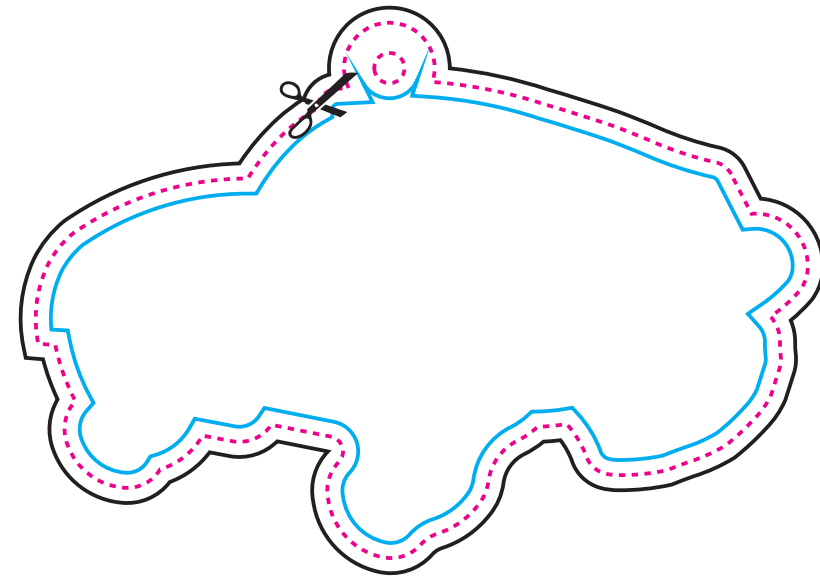

Retro

LINEA DEL TAGLIO



PROGETTO CON ABBONDAGGIO

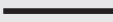

LINEA DI SICUREZZA (tutti gli elementi importanti devono essere inseriti all'interno di questa linea)

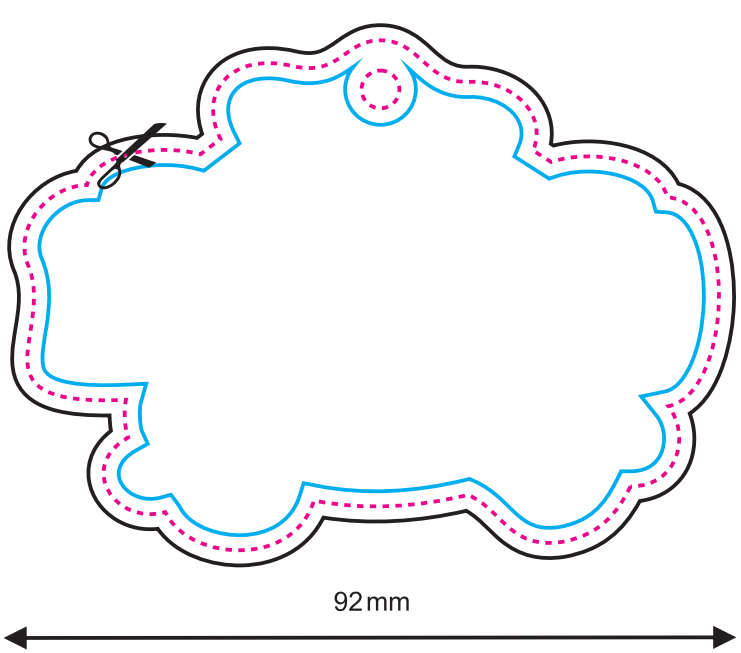

Fronte

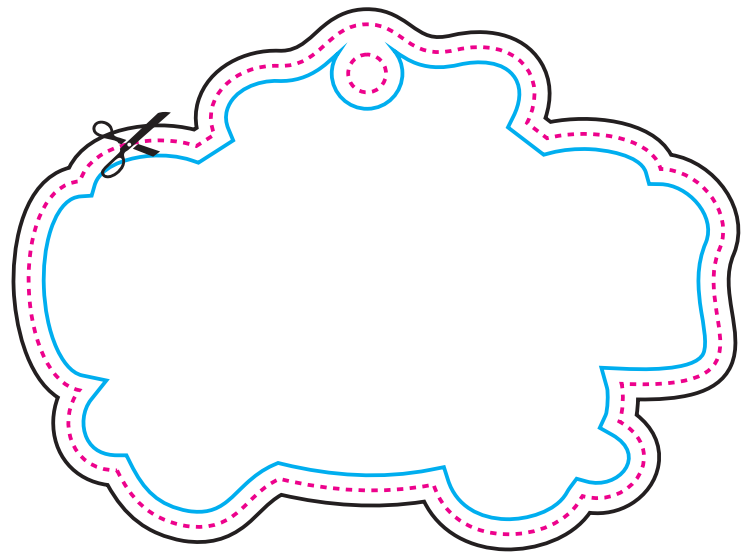

Retro

LINEA DEL TAGLIO



PROGETTO CON ABBONDAGGIO

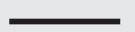

LINEA DI SICUREZZA (tutti gli elementi importanti devono essere inseriti all'interno di questa linea)

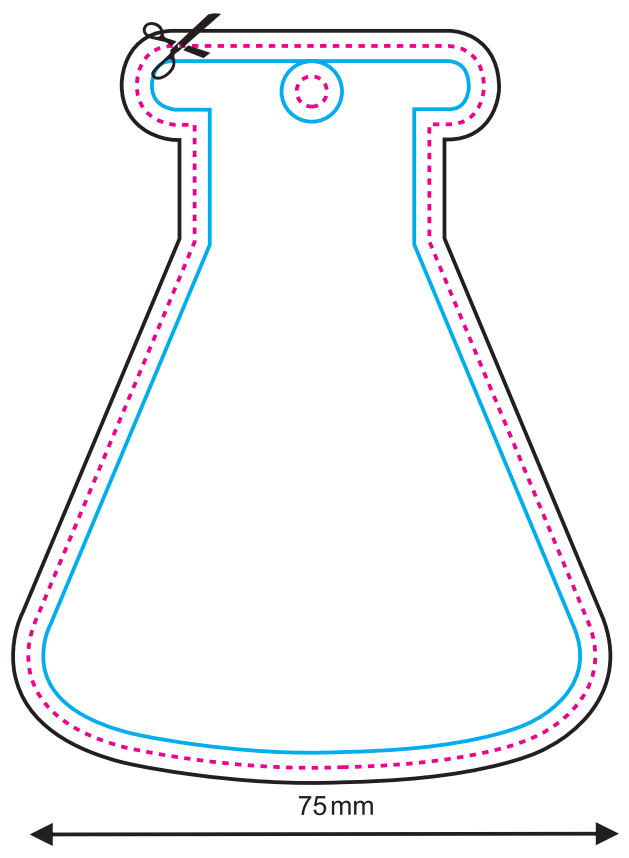

Fronte

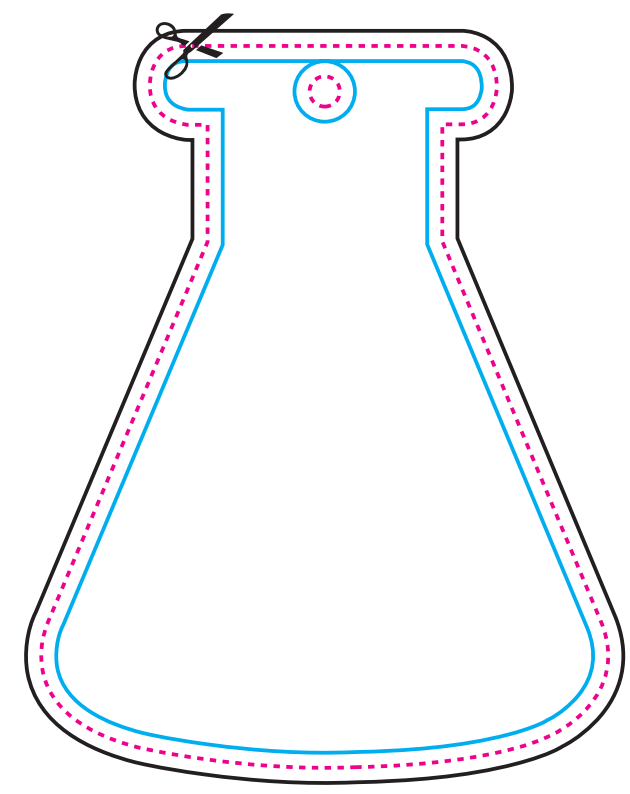

Retro

LINEA DEL TAGLIO



PROGETTO CON ABBONDAGGIO

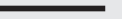

LINEA DI SICUREZZA (tutti gli elementi importanti devono essere inseriti all'interno di questa linea)

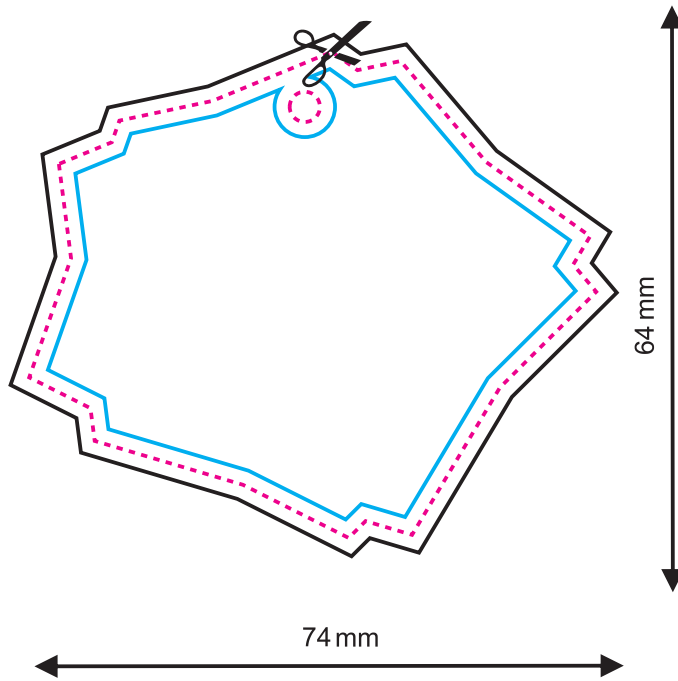

Fronte

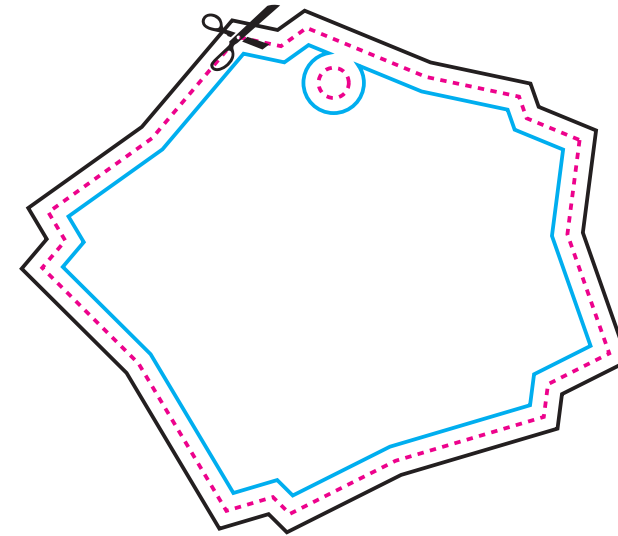

Retro

LINEA DEL TAGLIO



PROGETTO CON ABBONDAGGIO

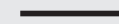

LINEA DI SICUREZZA (tutti gli elementi importanti devono essere inseriti all'interno di questa linea)

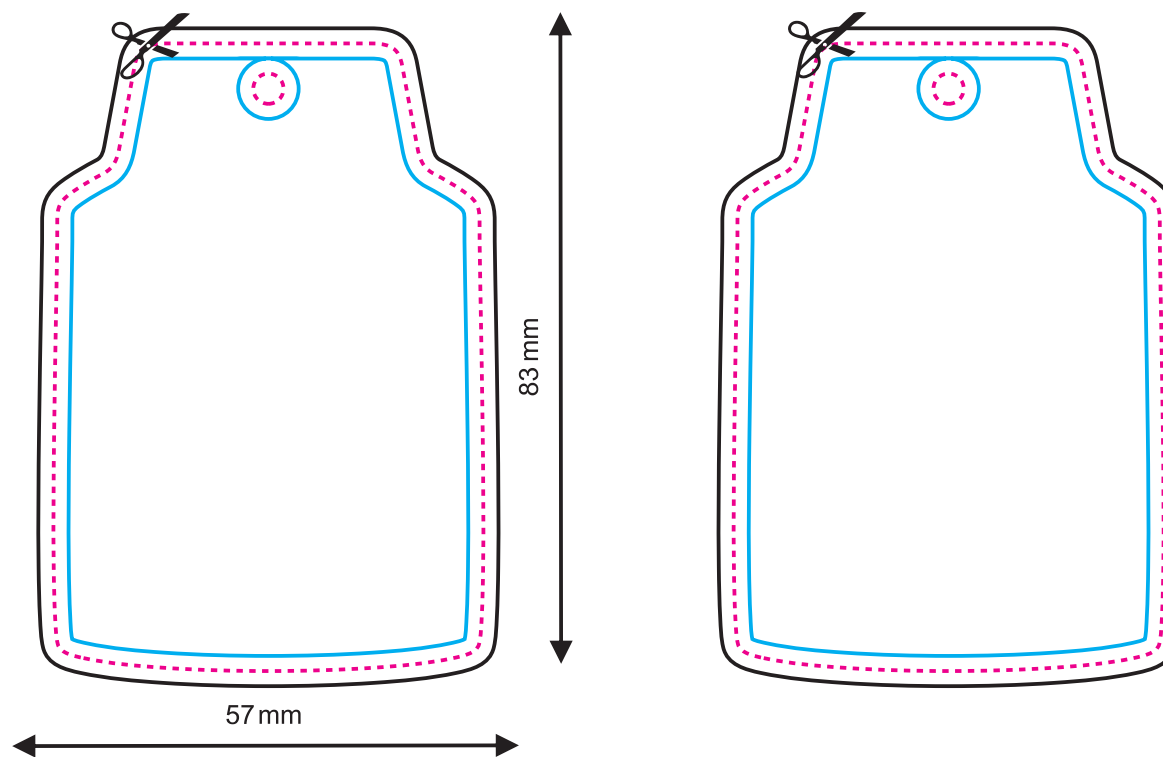
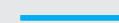

Fronte

Retro



622

LEGENDA

LINEA DEL TAGLIO



PROGETTO CON ABBONDAGGIO

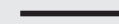

LINEA DI SICUREZZA (tutti gli elementi importanti devono essere inseriti all'interno di questa linea)

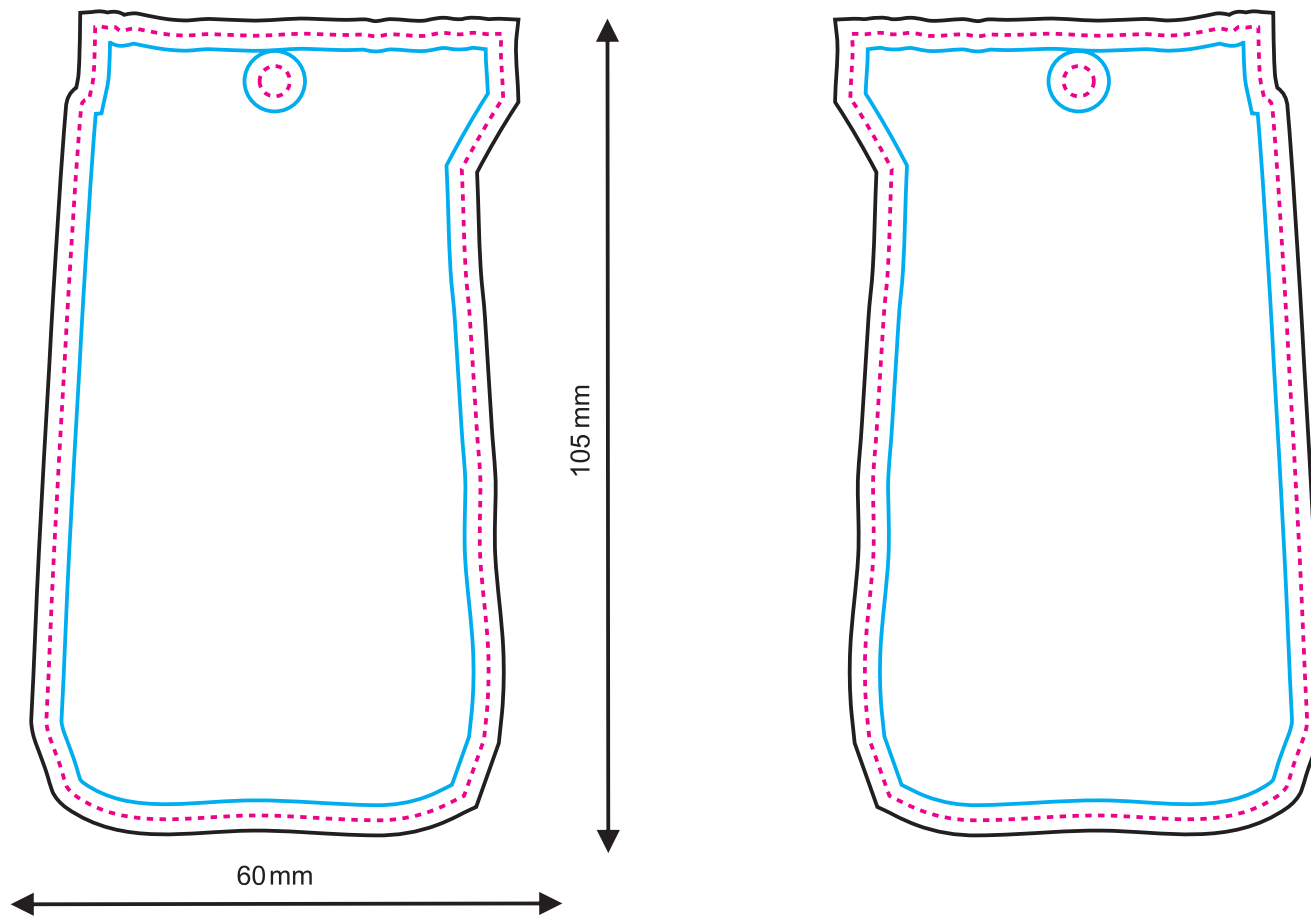
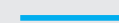

Fronte

Retro

LINEA DEL TAGLIO



PROGETTO CON ABBONDAGGIO



LINEA DI SICUREZZA (tutti gli elementi importanti devono essere inseriti all'interno di questa linea)

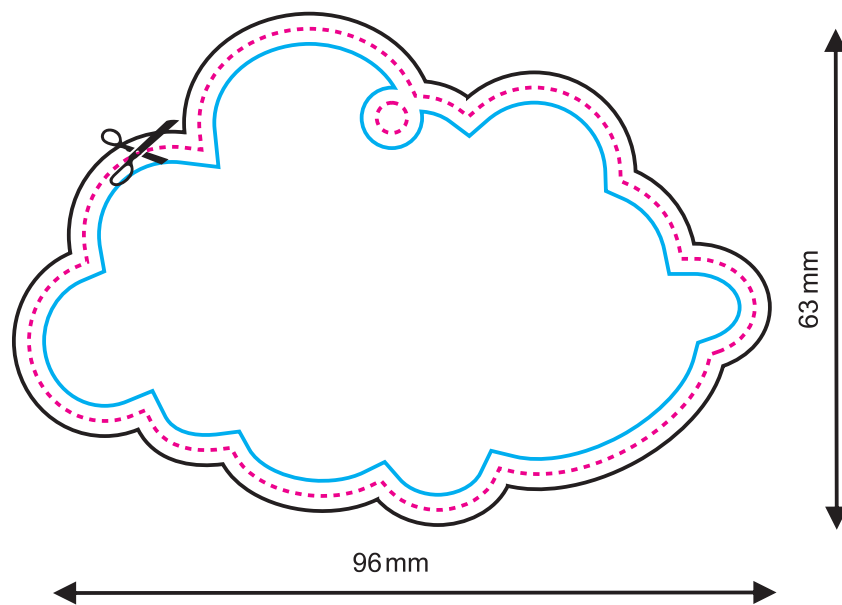

Fronte

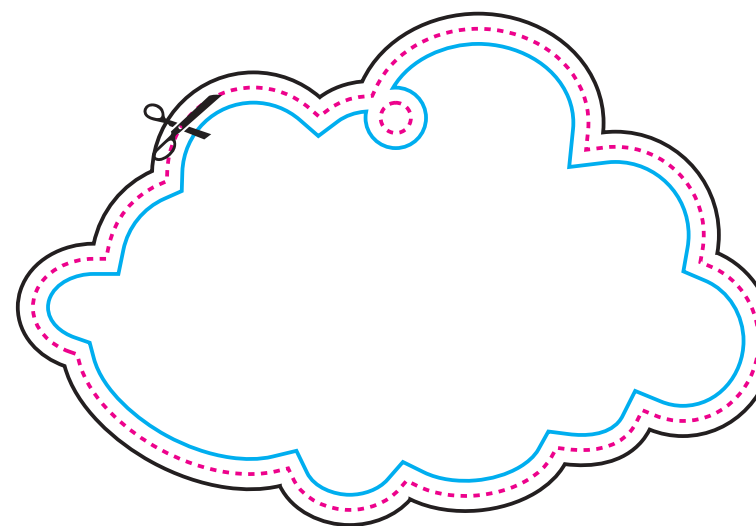

Retro

LINEA DEL TAGLIO



PROGETTO CON ABBONDAGGIO



LINEA DI SICUREZZA (tutti gli elementi importanti devono essere inseriti all'interno di questa linea)



Fronte

Retro

LINEA DEL TAGLIO



PROGETTO CON ABBONDAGGIO



LINEA DI SICUREZZA (tutti gli elementi importanti devono essere inseriti all'interno di questa linea)

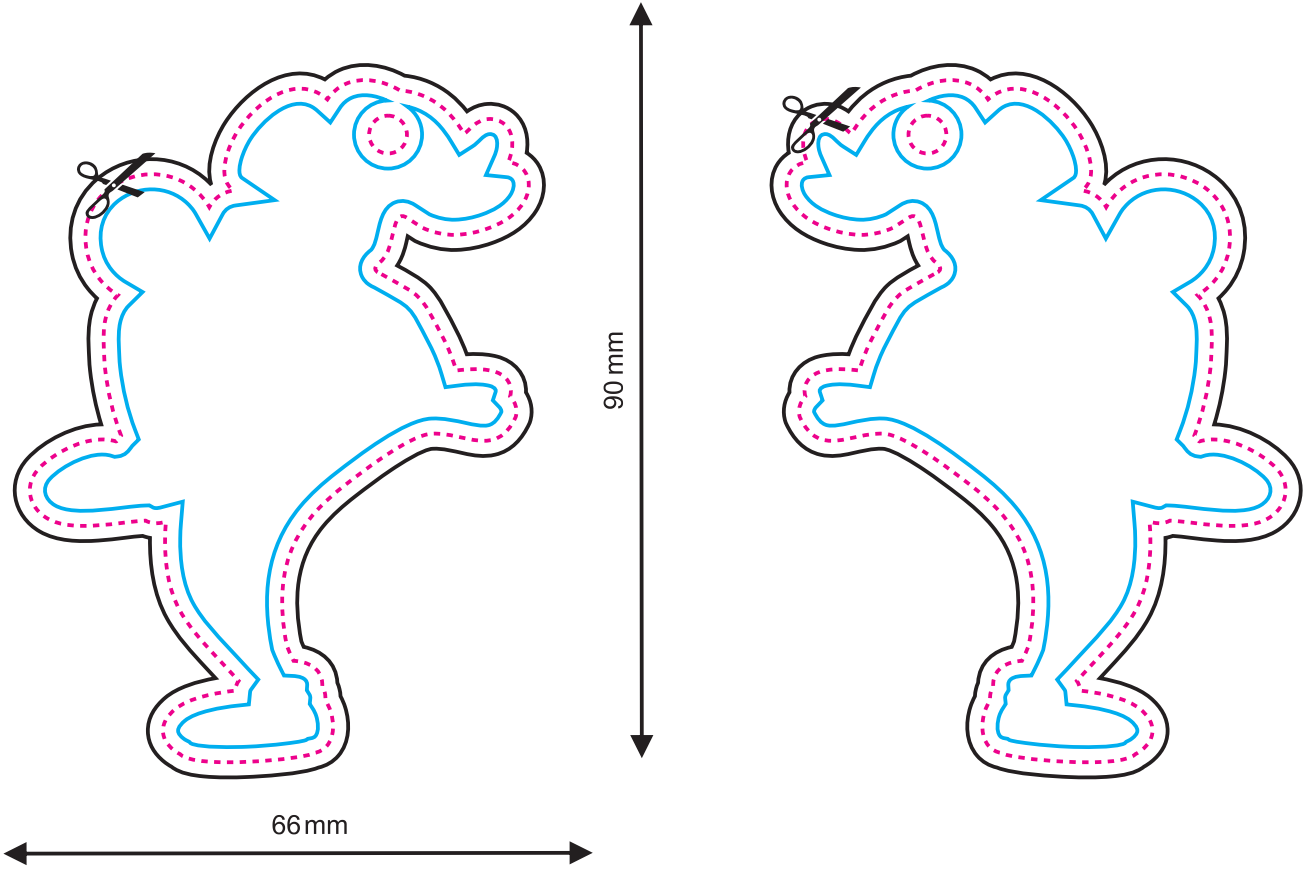
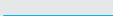

Fronte

Retro

LINEA DEL TAGLIO



PROGETTO CON ABBONDAGGIO

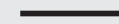

LINEA DI SICUREZZA (tutti gli elementi importanti devono essere inseriti all'interno di questa linea)

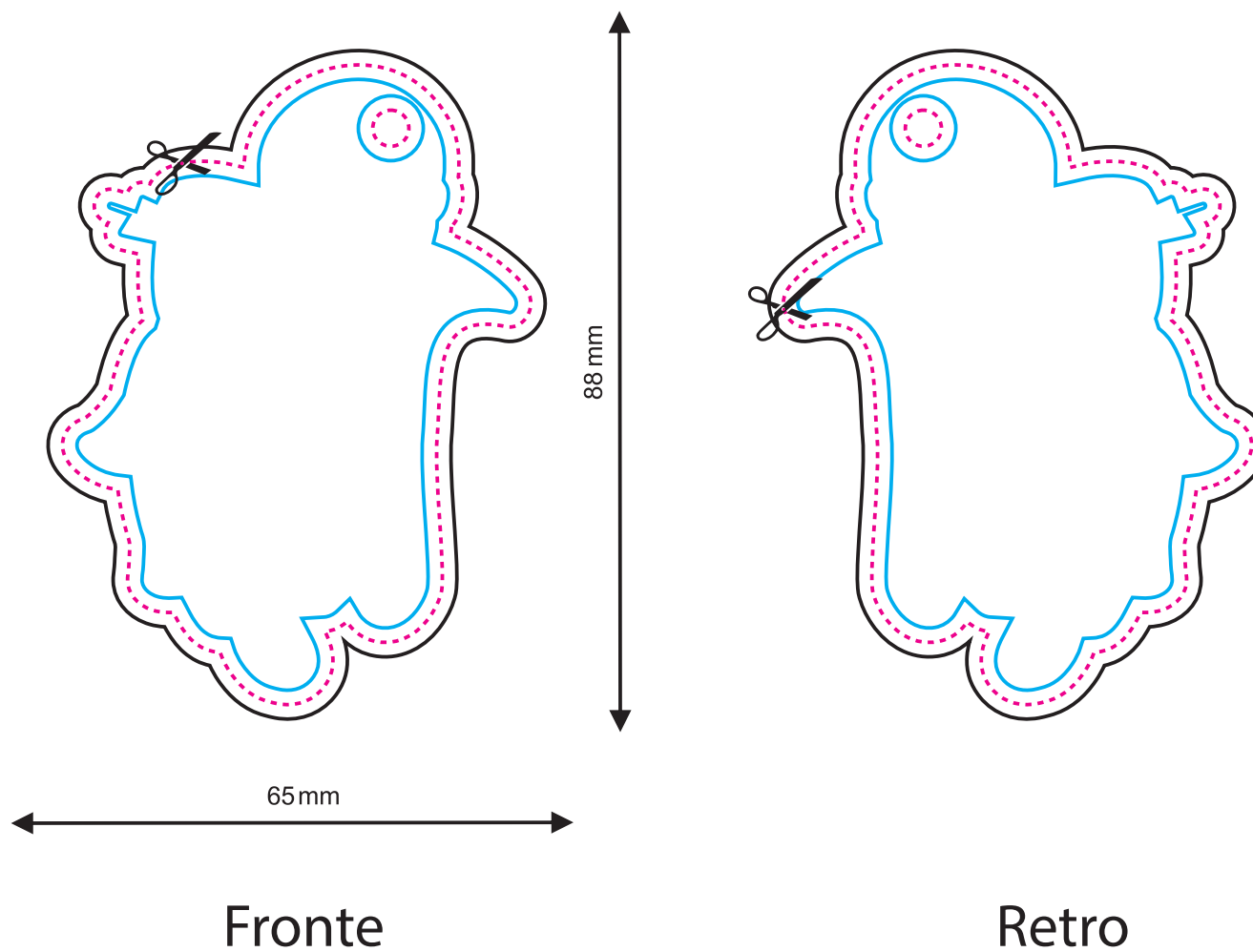
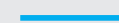

LINEA DEL TAGLIO



PROGETTO CON ABBONDAGGIO

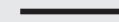

LINEA DI SICUREZZA (tutti gli elementi importanti devono essere inseriti all'interno di questa linea)

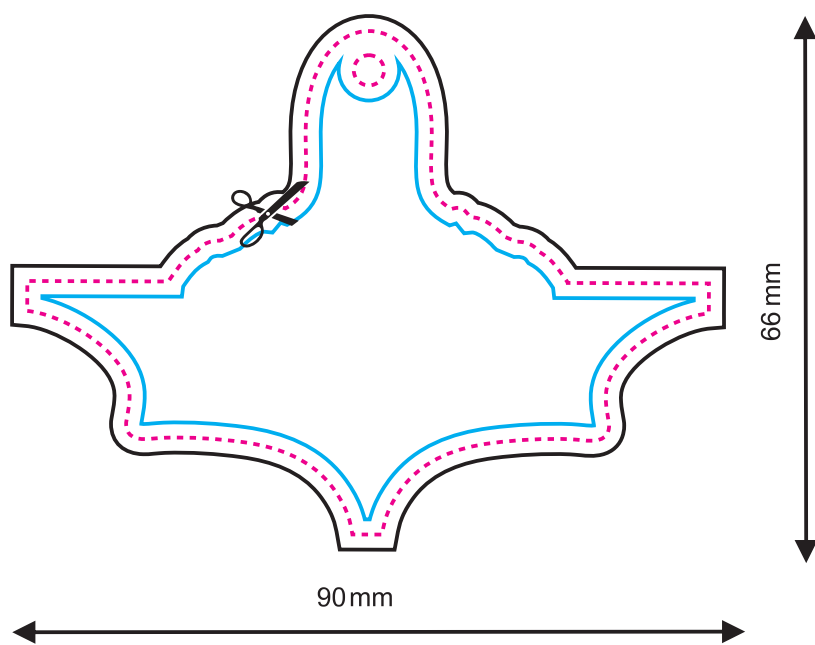

Fronte

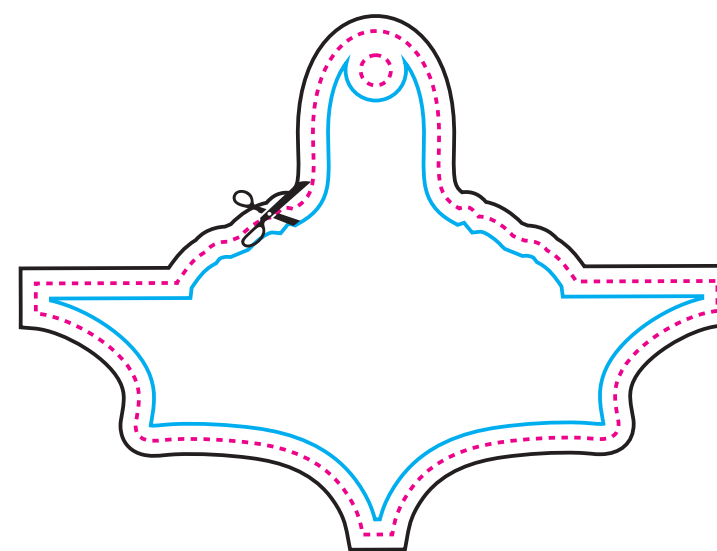

Retro

LINEA DEL TAGLIO



PROGETTO CON ABBONDAGGIO

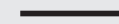

LINEA DI SICUREZZA (tutti gli elementi importanti devono essere inseriti all'interno di questa linea)

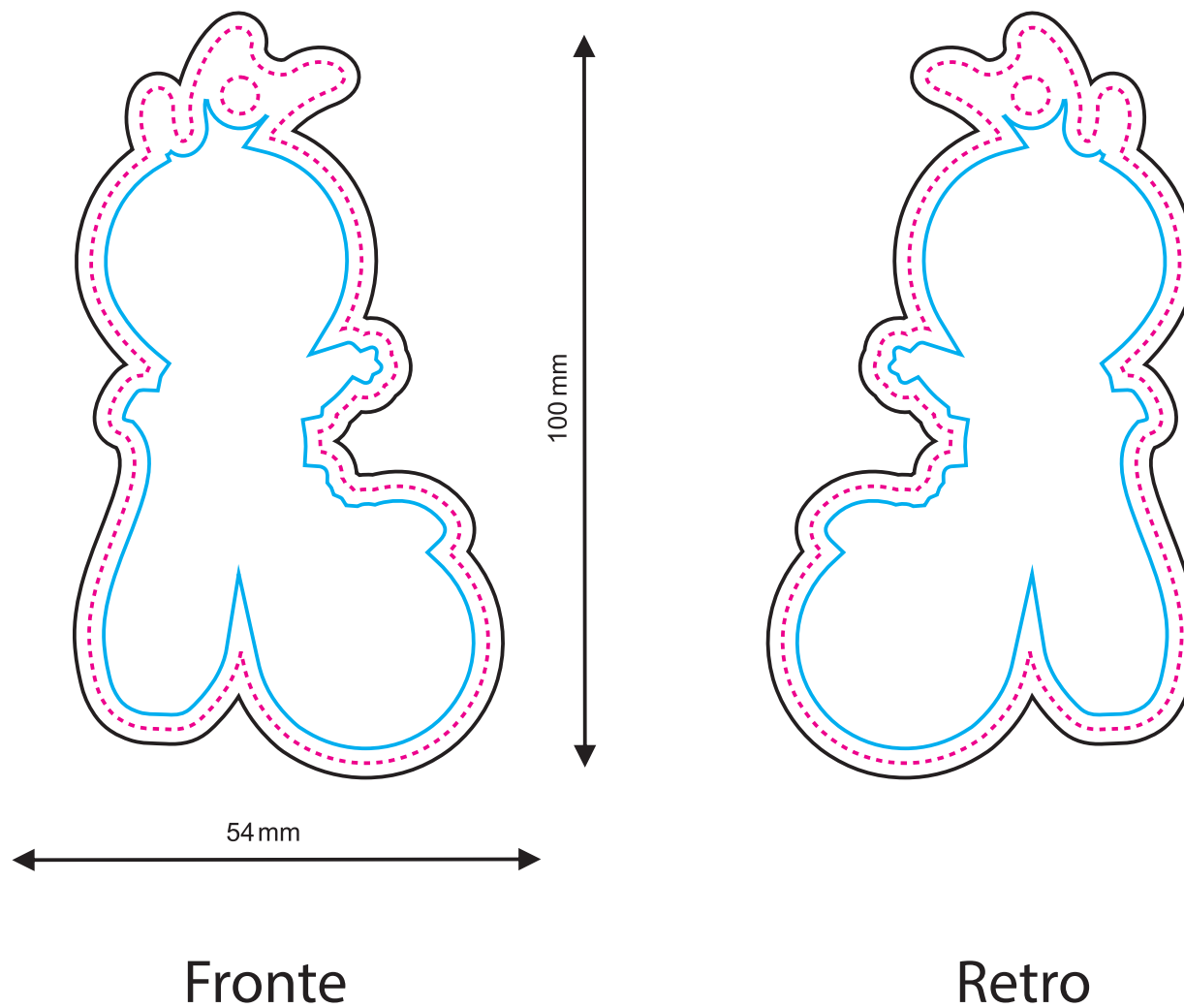
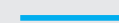

LINEA DEL TAGLIO



PROGETTO CON ABBONDAGGIO

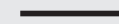

LINEA DI SICUREZZA (tutti gli elementi importanti devono essere inseriti all'interno di questa linea)

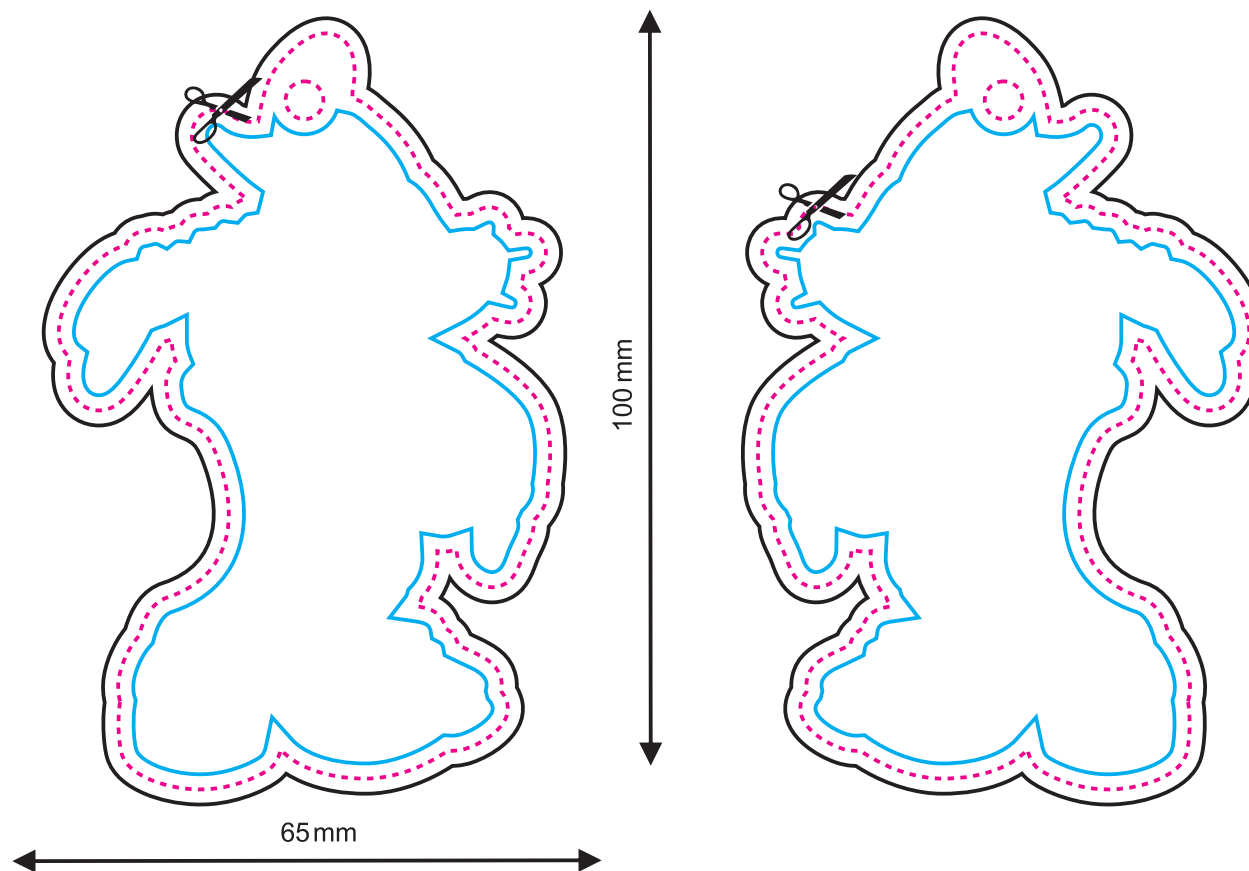
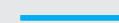

Fronte

Retro



LINEA DEL TAGLIO



PROGETTO CON ABBONDAGGIO

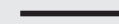

LINEA DI SICUREZZA (tutti gli elementi importanti devono essere inseriti all'interno di questa linea)

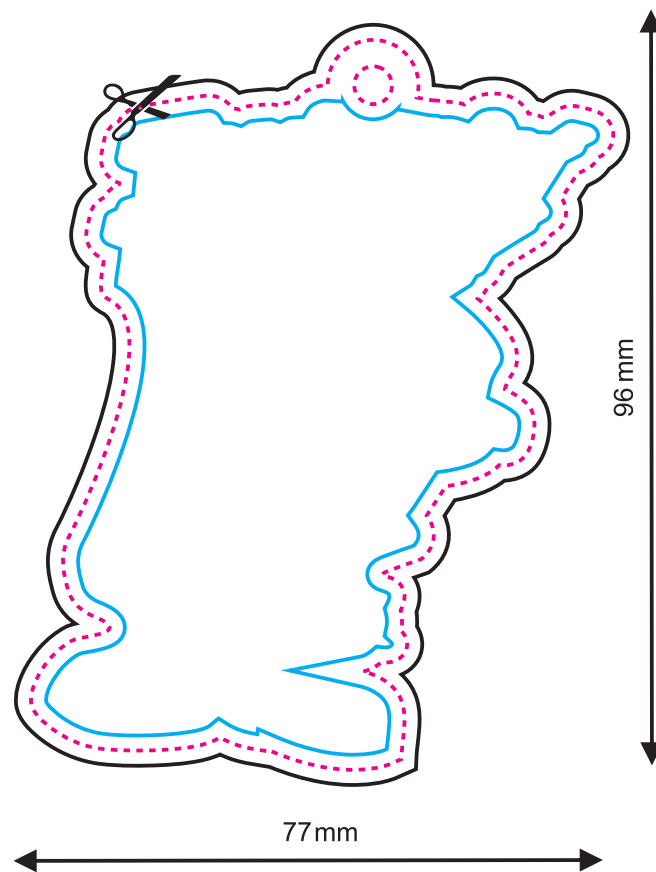
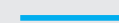

Fronte

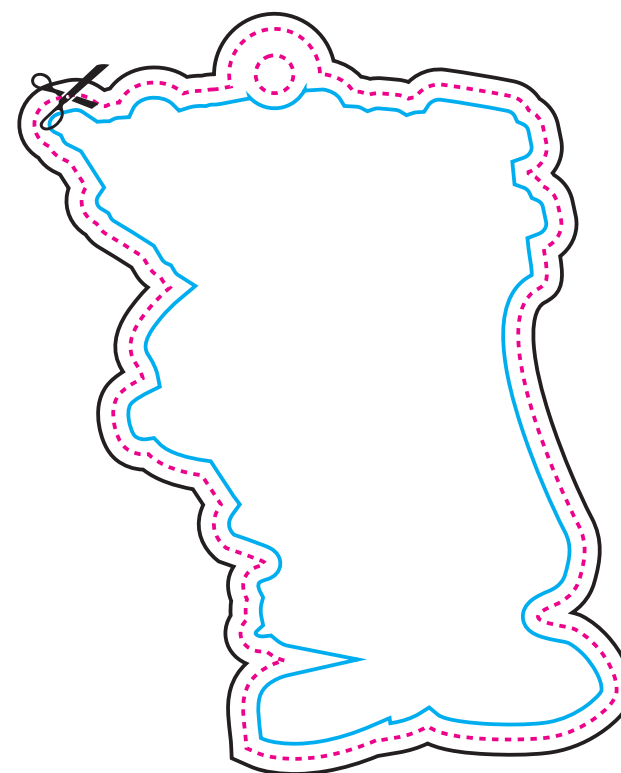

Retro

LINEA DEL TAGLIO



PROGETTO CON ABBONDAGGIO

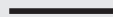

LINEA DI SICUREZZA (tutti gli elementi importanti devono essere inseriti all'interno di questa linea)

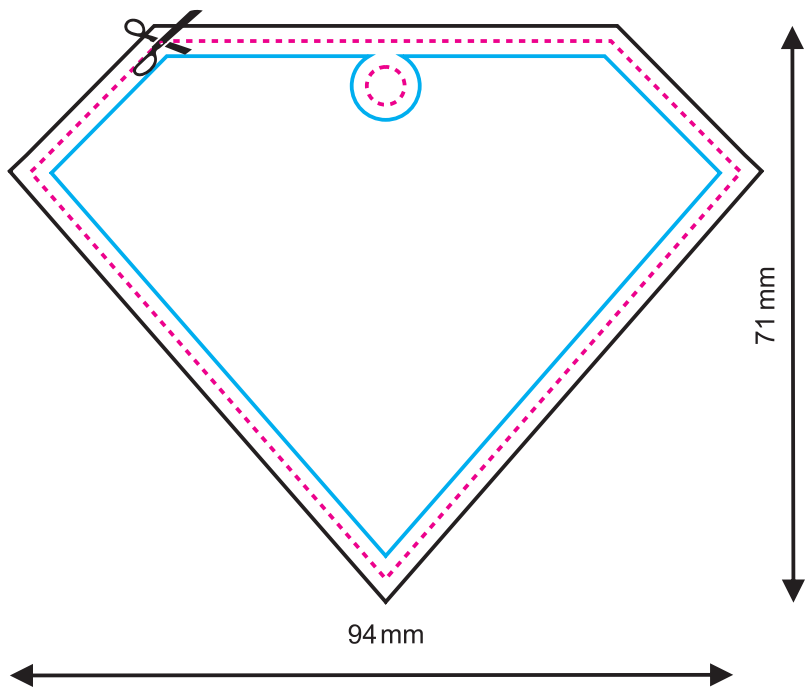

Fronte

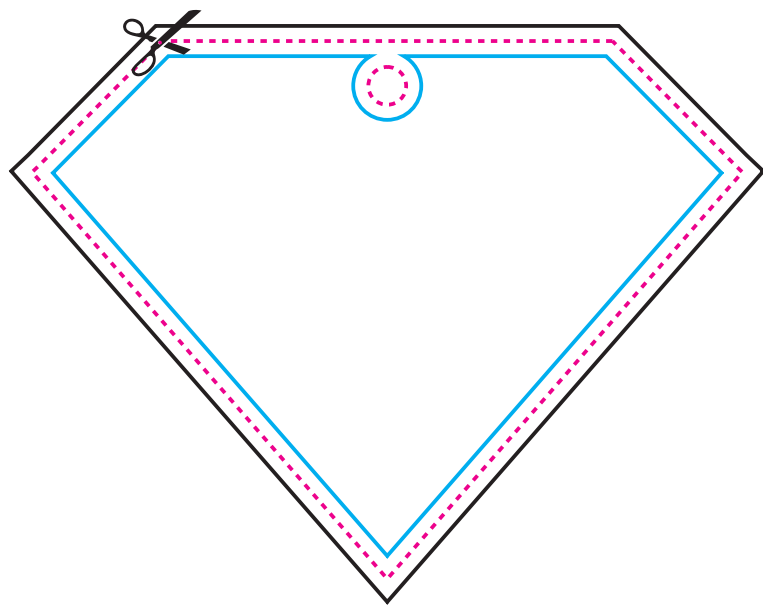

Retro

633

LEGENDA

LINEA DEL TAGLIO



PROGETTO CON ABBONDAGGIO

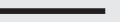

LINEA DI SICUREZZA (tutti gli elementi importanti devono essere inseriti all'interno di questa linea)

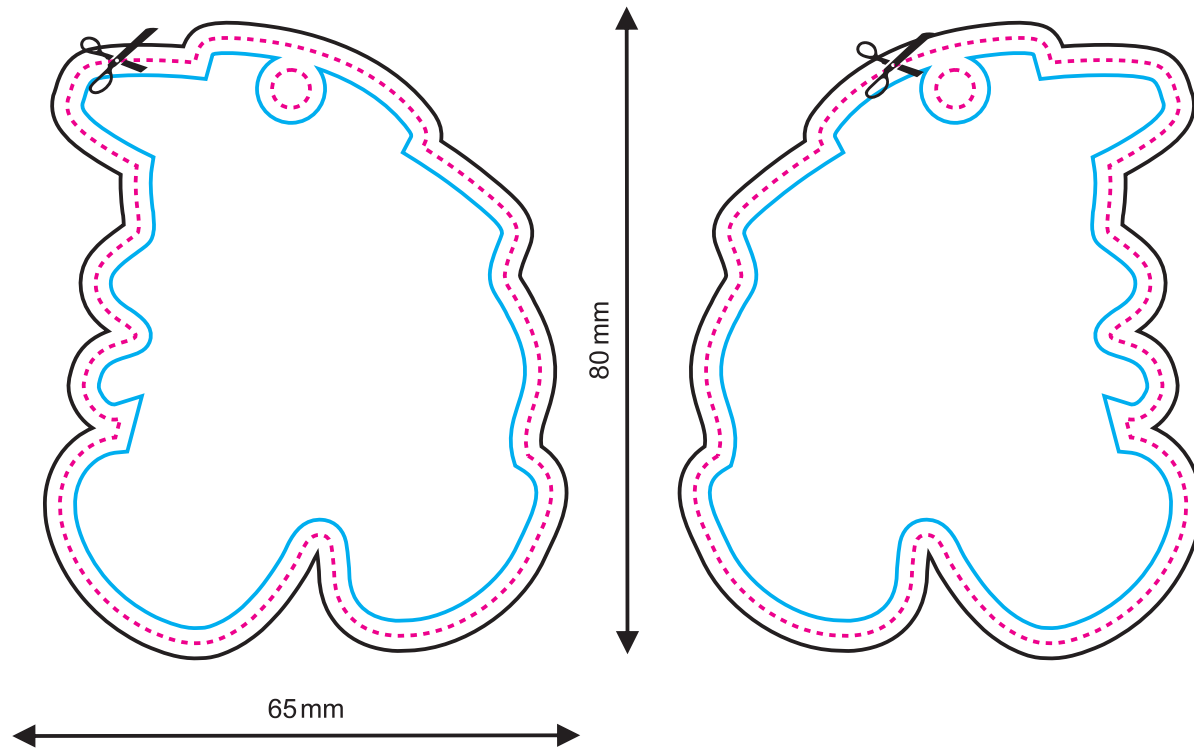
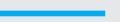

Fronte

Retro

LINEA DEL TAGLIO



PROGETTO CON ABBONDAGGIO

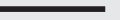

LINEA DI SICUREZZA (tutti gli elementi importanti devono essere inseriti all'interno di questa linea)

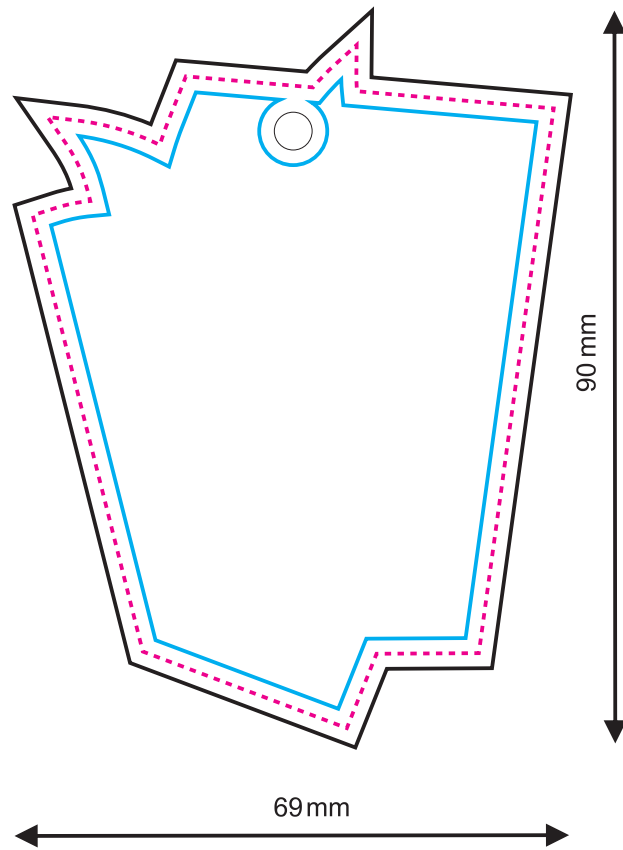
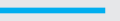

Fronte

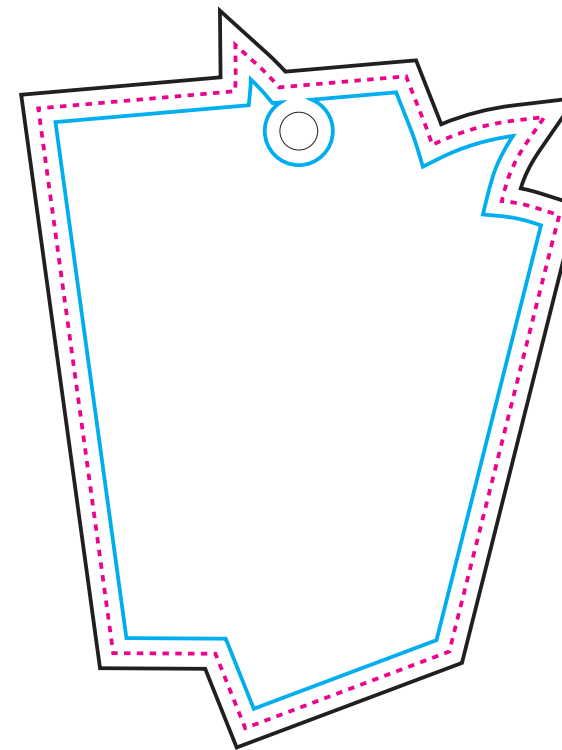

Retro

635

LEGENDA

LINEA DEL TAGLIO



PROGETTO CON ABBONDAGGIO

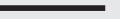

LINEA DI SICUREZZA (tutti gli elementi importanti devono essere inseriti all'interno di questa linea)

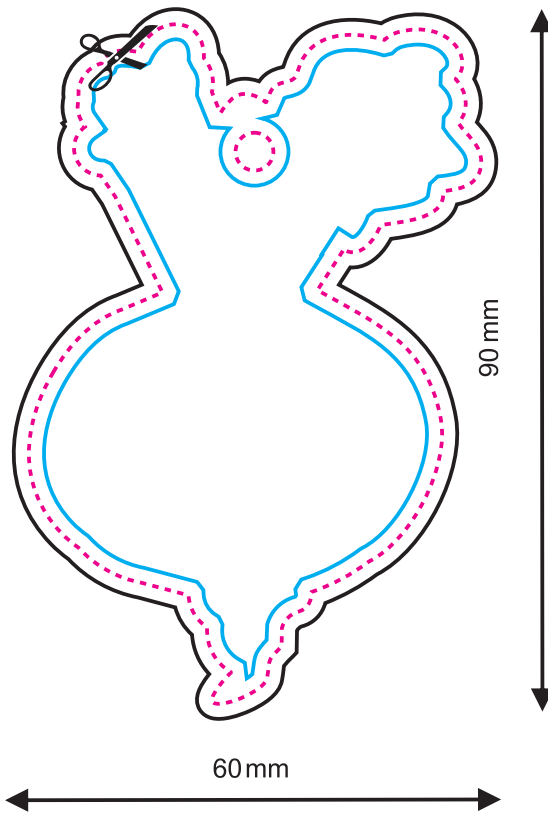

Fronte

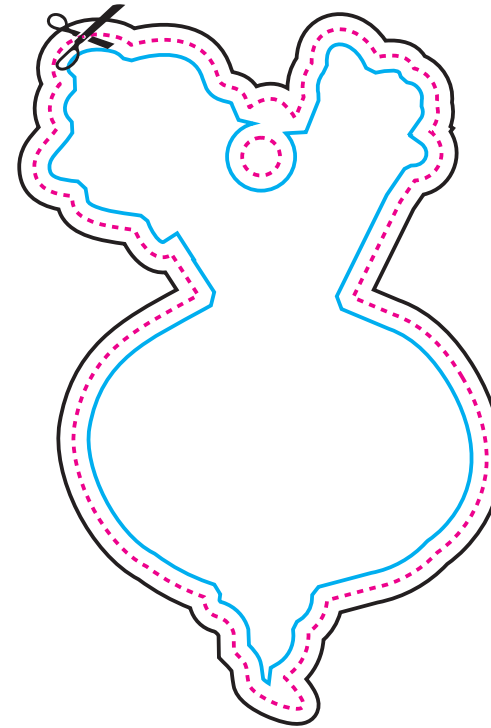

Retro

LINEA DEL TAGLIO



PROGETTO CON ABBONDAGGIO

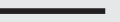

LINEA DI SICUREZZA (tutti gli elementi importanti devono essere inseriti all'interno di questa linea)

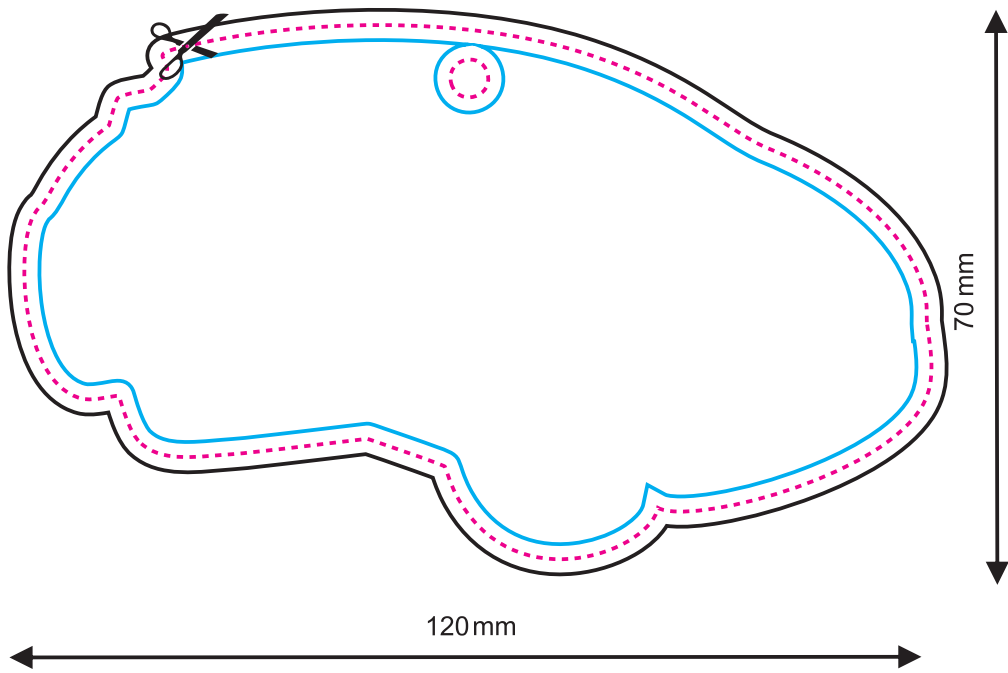
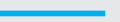

Fronte

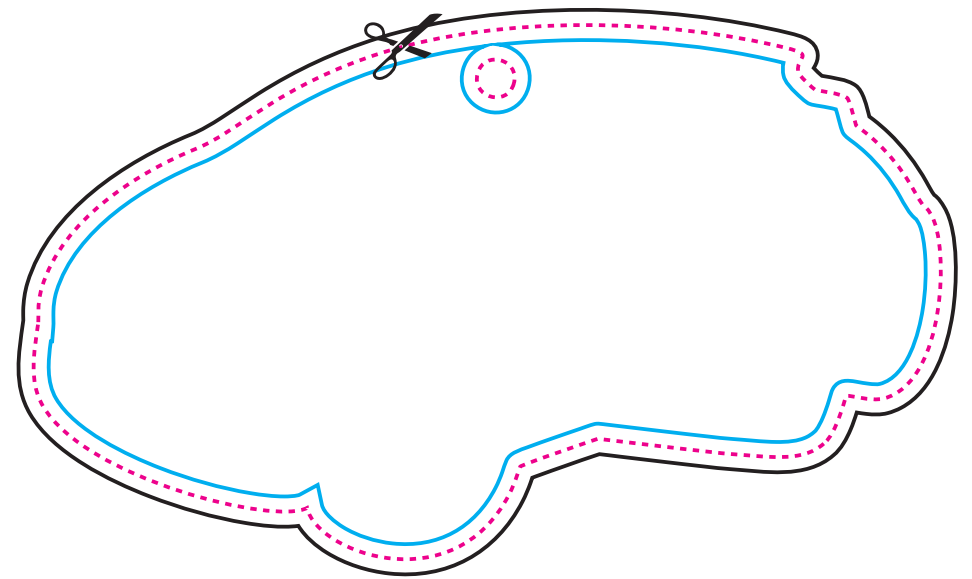

Retro

LINEA DEL TAGLIO



PROGETTO CON ABBONDAGGIO

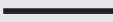

LINEA DI SICUREZZA (tutti gli elementi importanti devono essere inseriti all'interno di questa linea)

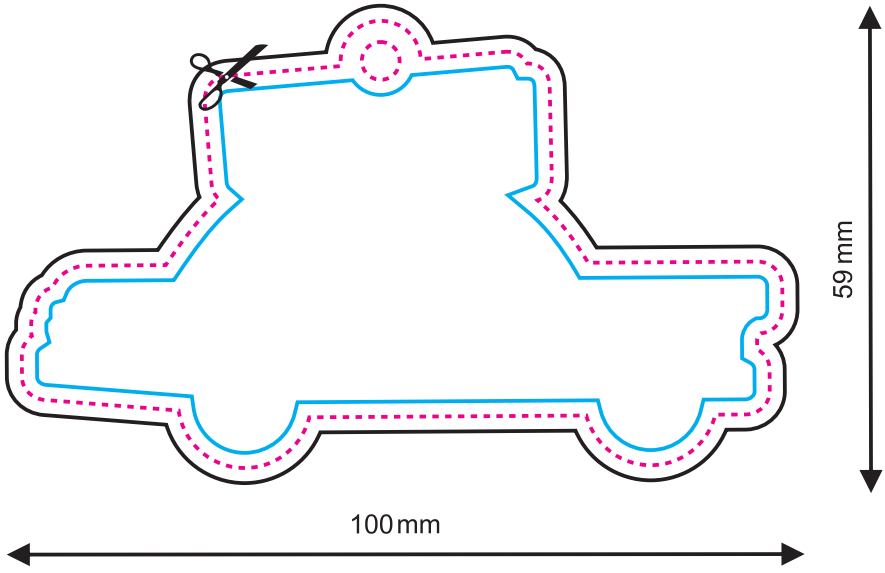
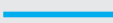

Fronte

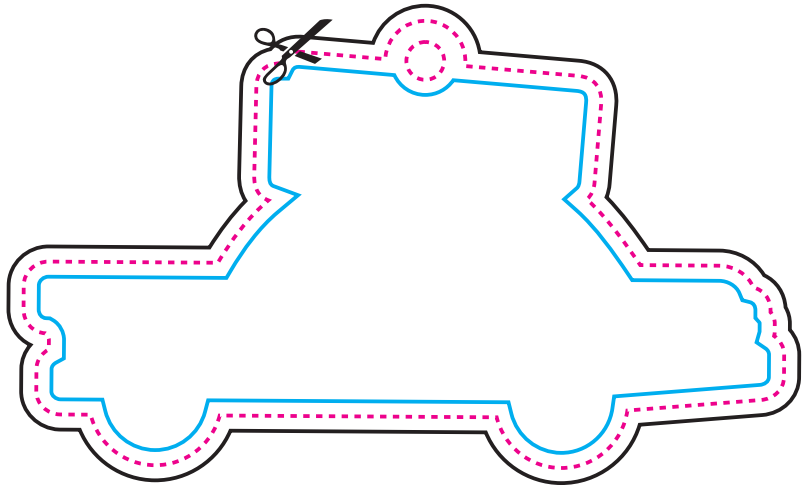

Retro

638

LEGENDA

LINEA DEL TAGLIO



PROGETTO CON ABBONDAGGIO

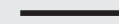

LINEA DI SICUREZZA (tutti gli elementi importanti devono essere inseriti all'interno di questa linea)

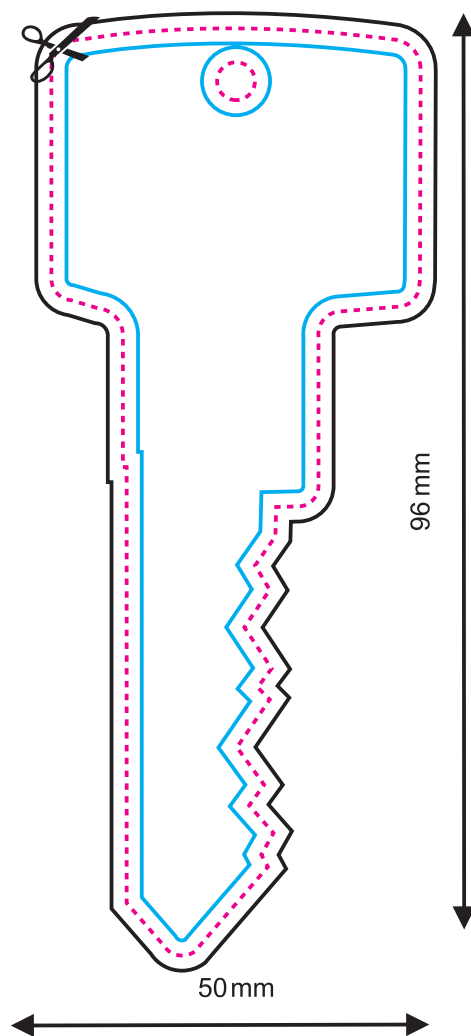
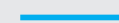

Fronte

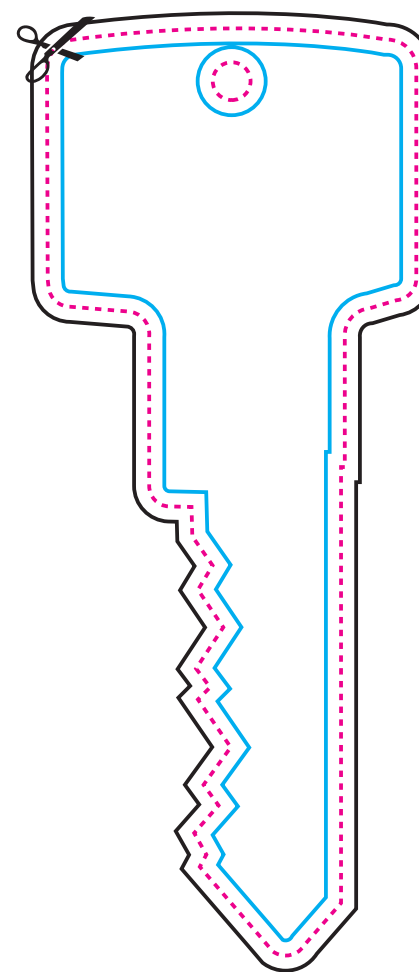

Retro



LINEA DEL TAGLIO



PROGETTO CON ABBONDAGGIO

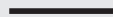

LINEA DI SICUREZZA (tutti gli elementi importanti devono essere inseriti all'interno di questa linea)

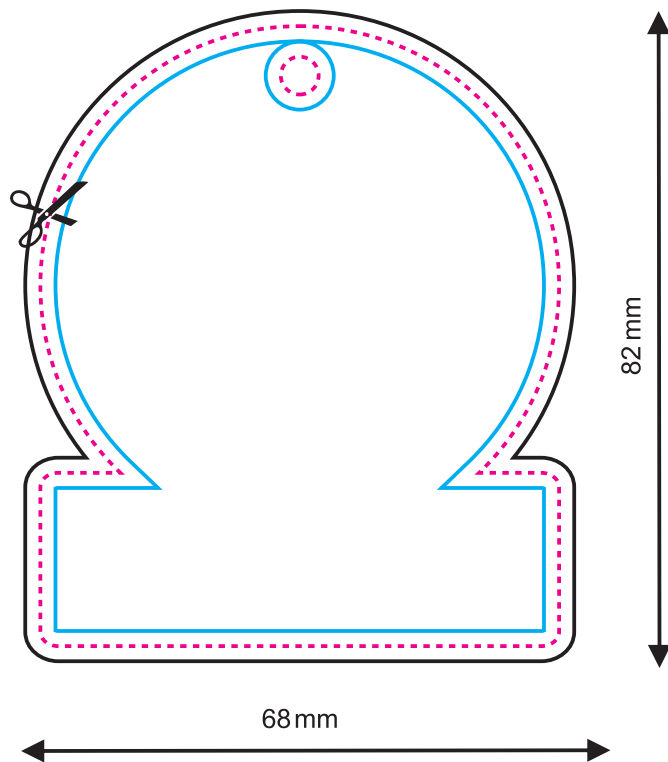

Fronte

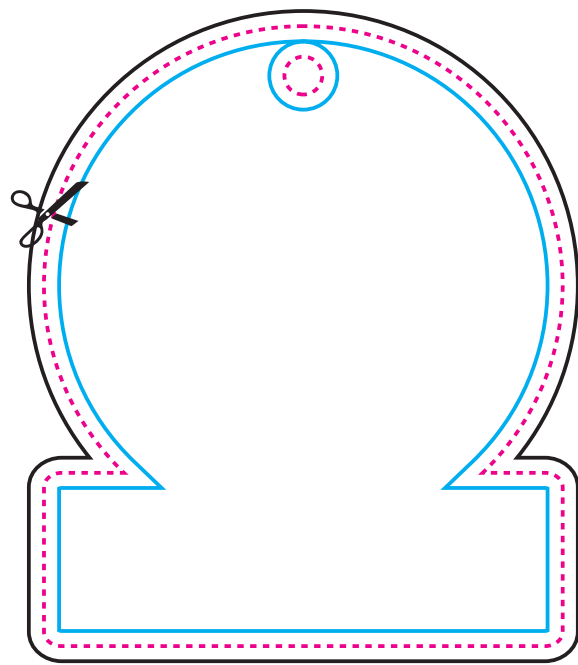

Retro

LINEA DEL TAGLIO



PROGETTO CON ABBONDAGGIO



LINEA DI SICUREZZA (tutti gli elementi importanti devono essere inseriti all'interno di questa linea)

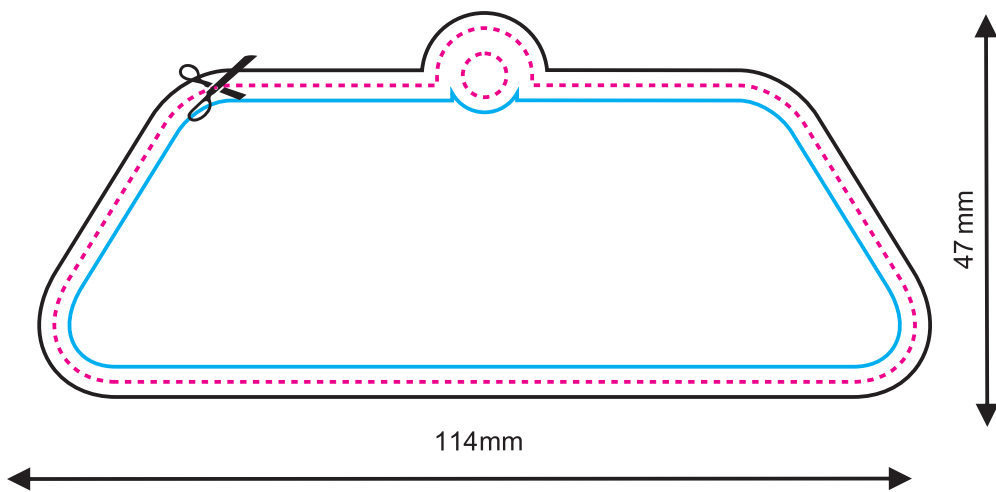
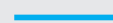

Fronte

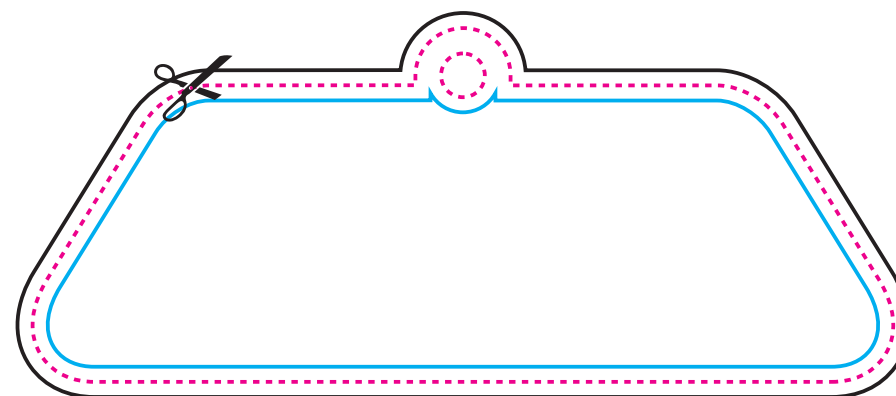

Retro

641

LEGENDA

LINEA DEL TAGLIO



PROGETTO CON ABBONDAGGIO

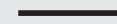

LINEA DI SICUREZZA (tutti gli elementi importanti devono essere inseriti all'interno di questa linea)

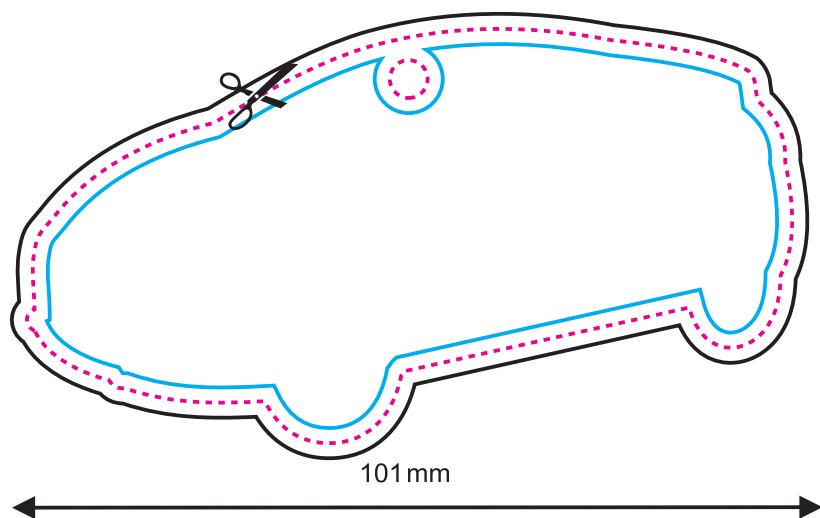
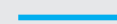

Fronte

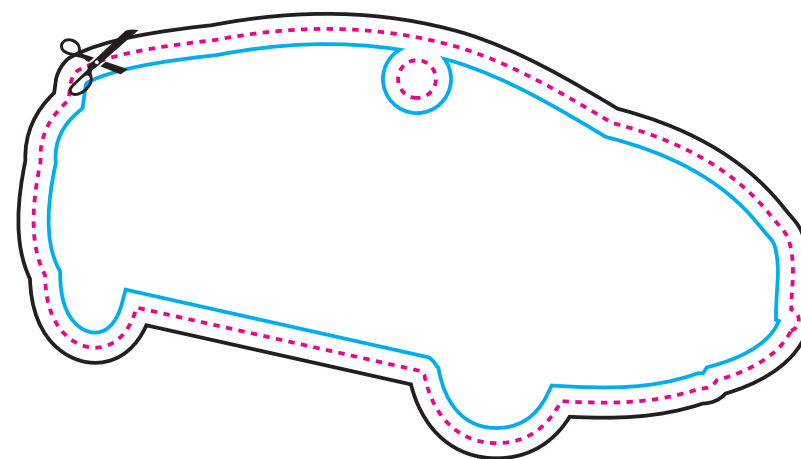

Retro

LINEA DEL TAGLIO



PROGETTO CON ABBONDAGGIO

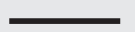

LINEA DI SICUREZZA (tutti gli elementi importanti devono essere inseriti all'interno di questa linea)

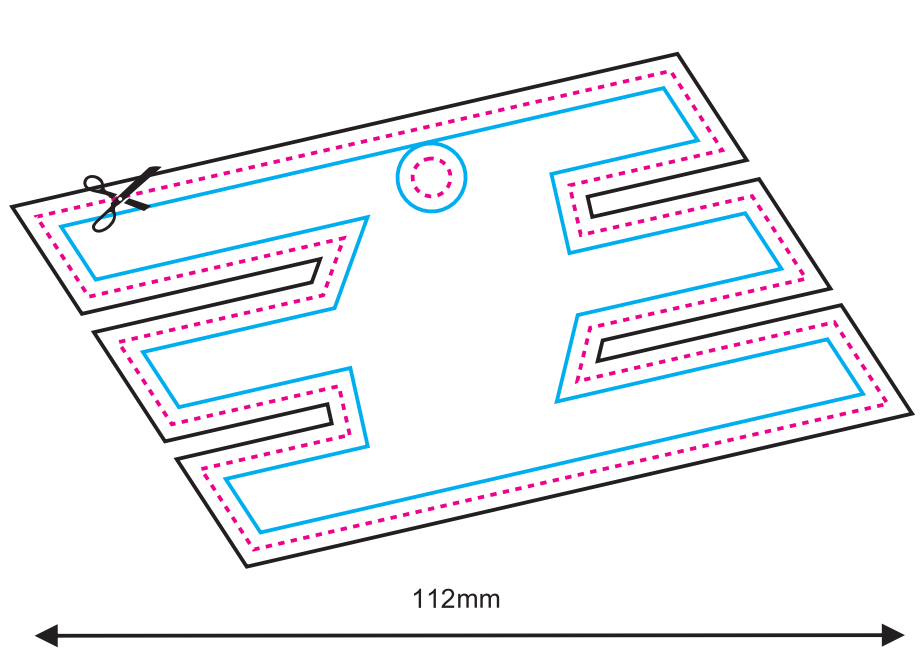

Fronte

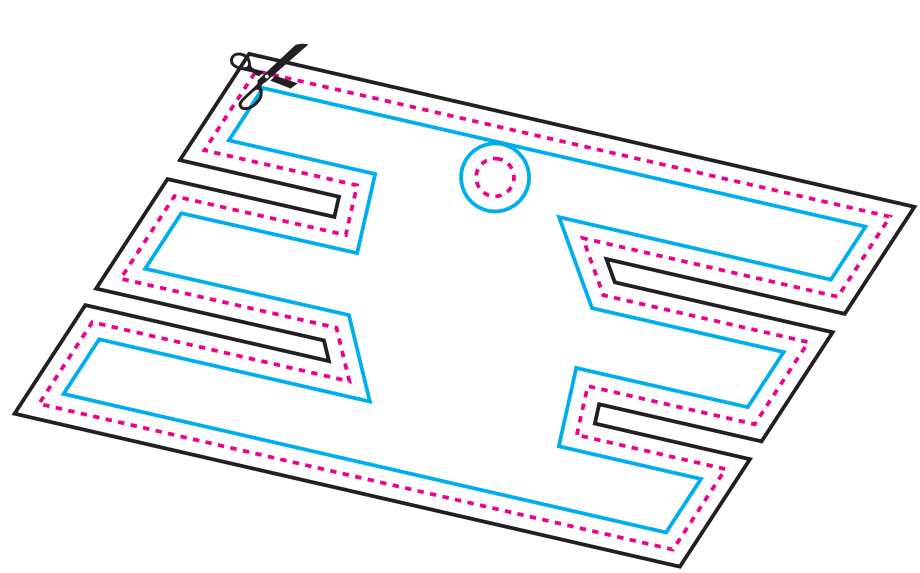

Retro

LINEA DEL TAGLIO



PROGETTO CON ABBONDAGGIO



LINEA DI SICUREZZA (tutti gli elementi importanti devono essere inseriti all'interno di questa linea)

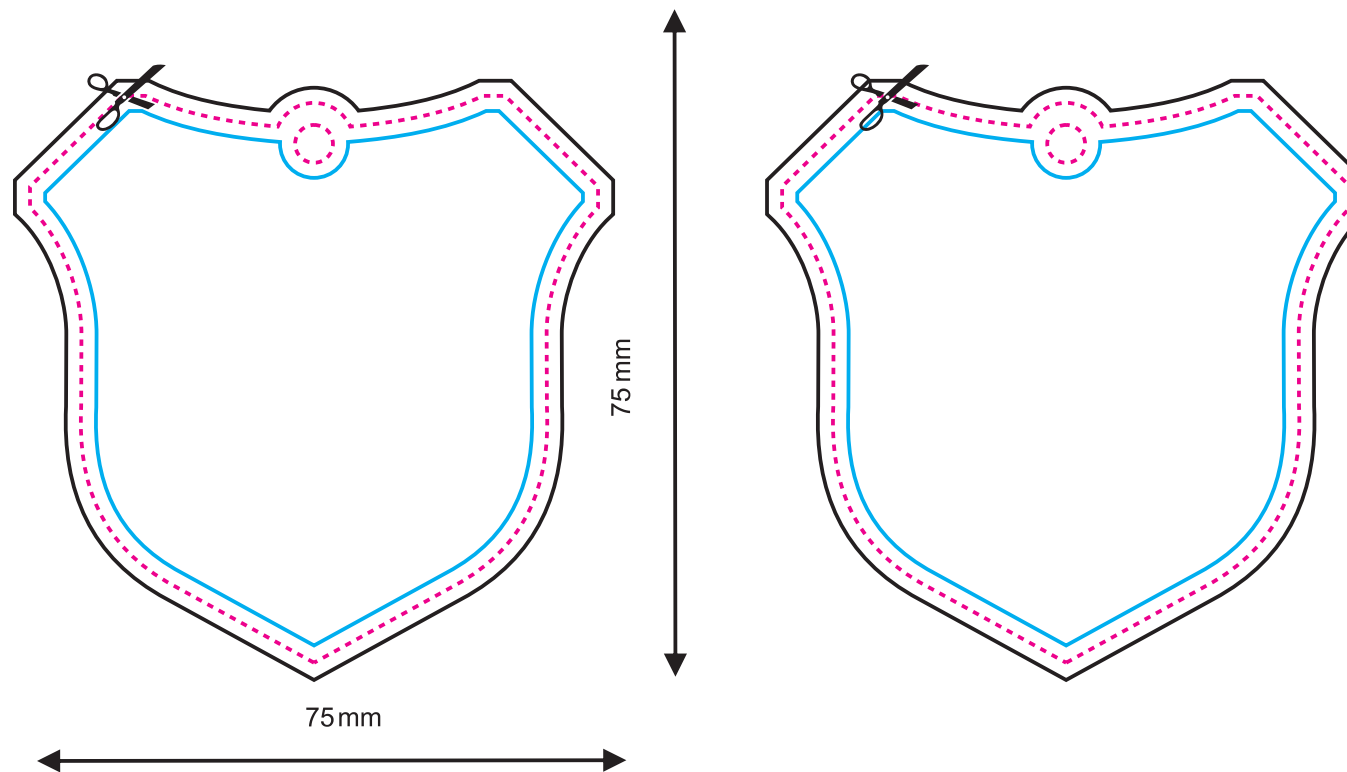
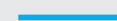

Fronte

Retro

LINEA DEL TAGLIO



PROGETTO CON ABBONDAGGIO



LINEA DI SICUREZZA (tutti gli elementi importanti devono essere inseriti all'interno di questa linea)

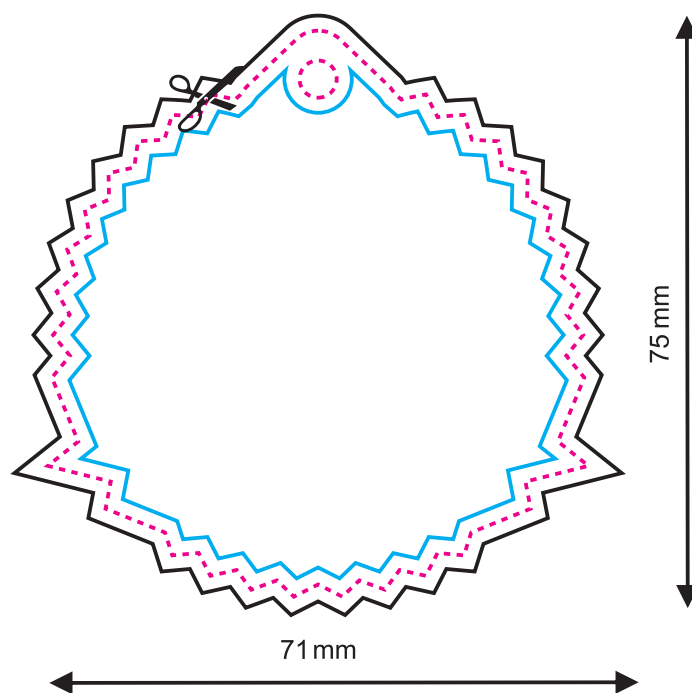

Fronte

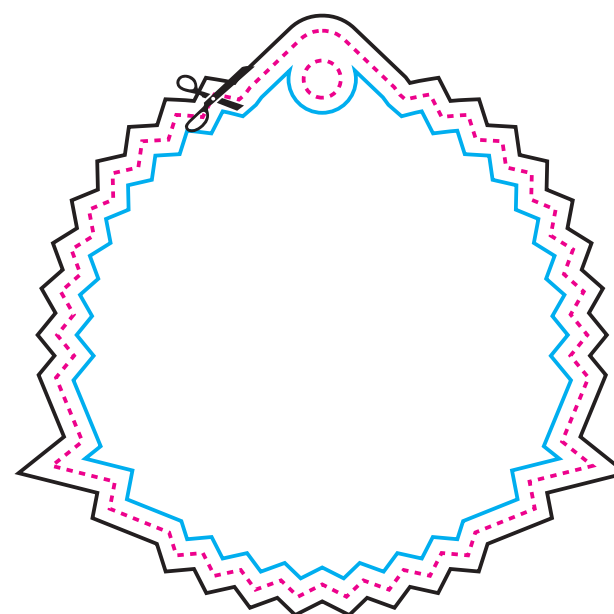

Retro

LINEA DEL TAGLIO



PROGETTO CON ABBONDAGGIO

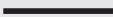

LINEA DI SICUREZZA (tutti gli elementi importanti devono essere inseriti all'interno di questa linea)

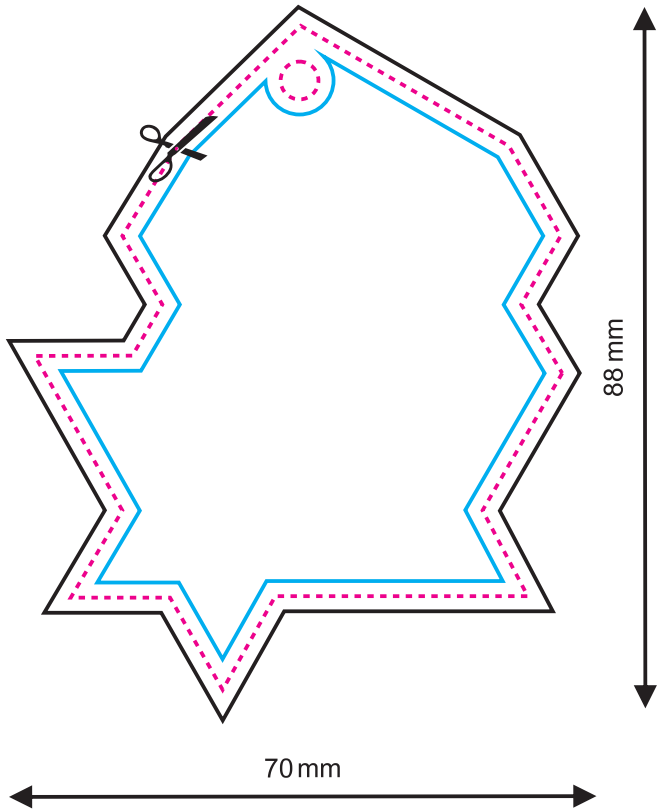

Fronte

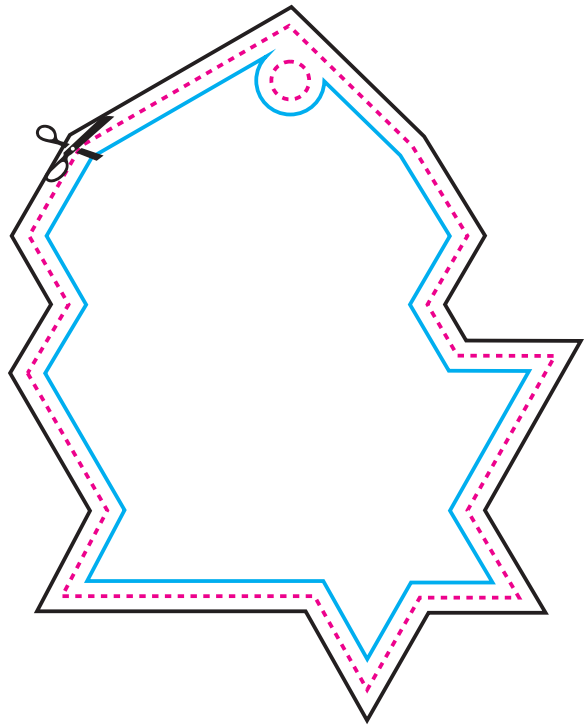

Retro

LINEA DEL TAGLIO



PROGETTO CON ABBONDAGGIO

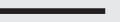

LINEA DI SICUREZZA (tutti gli elementi importanti devono essere inseriti all'interno di questa linea)

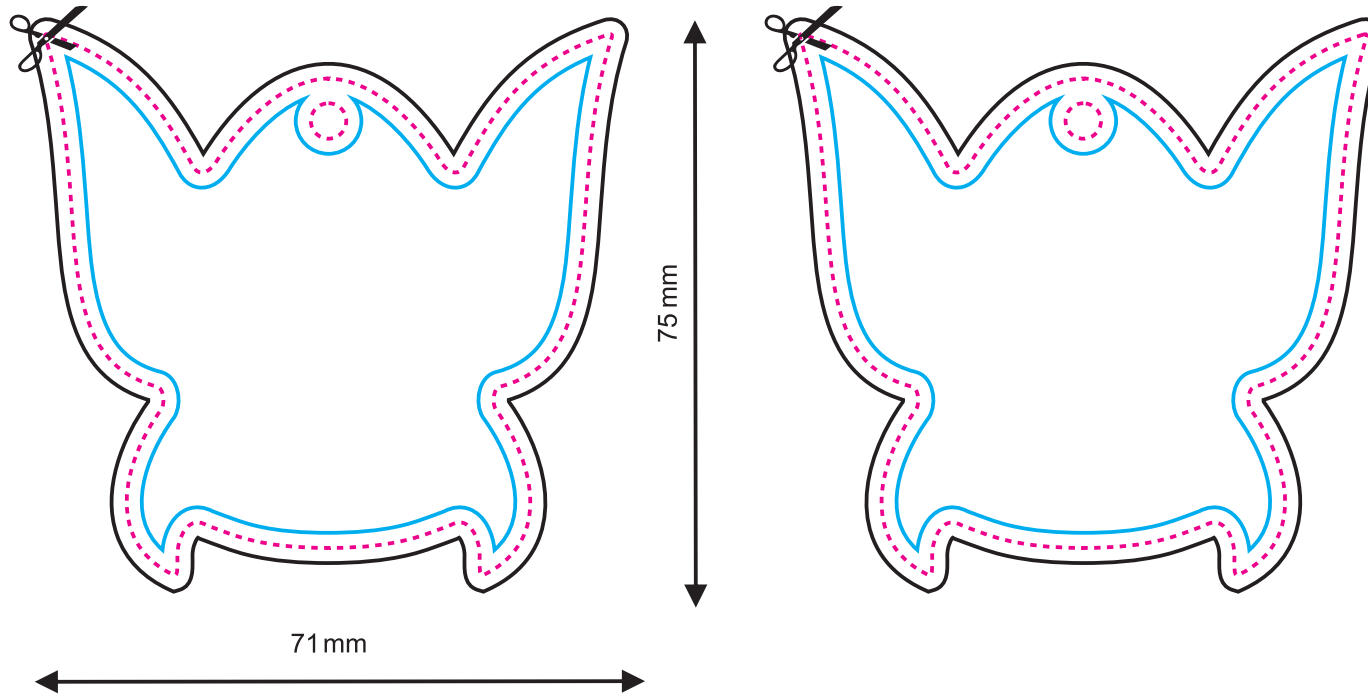
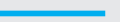

Fronte

Retro



LINEA DEL TAGLIO



PROGETTO CON ABBONDAGGIO

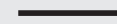

LINEA DI SICUREZZA (tutti gli elementi importanti devono essere inseriti all'interno di questa linea)

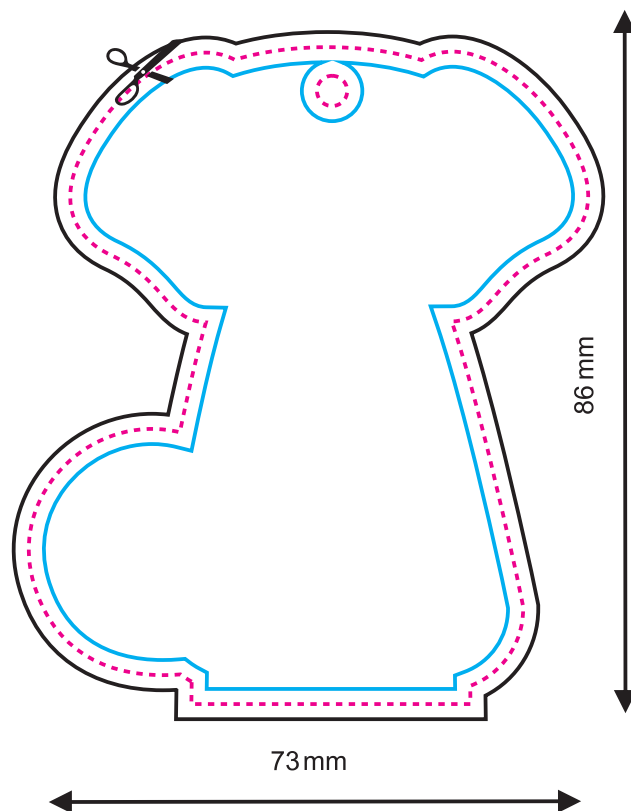

Fronte

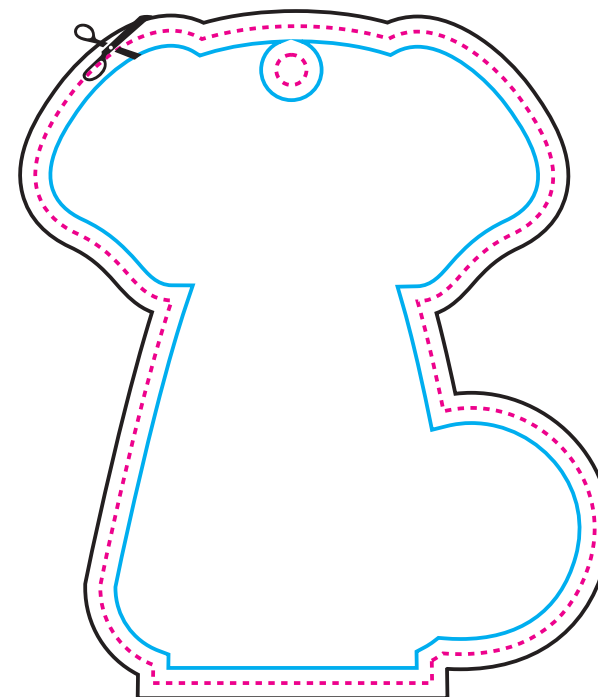

Retro

663

LEGENDA

LINEA DEL TAGLIO



PROGETTO CON ABBONDAGGIO



LINEA DI SICUREZZA (tutti gli elementi importanti devono essere inseriti all'interno di questa linea)

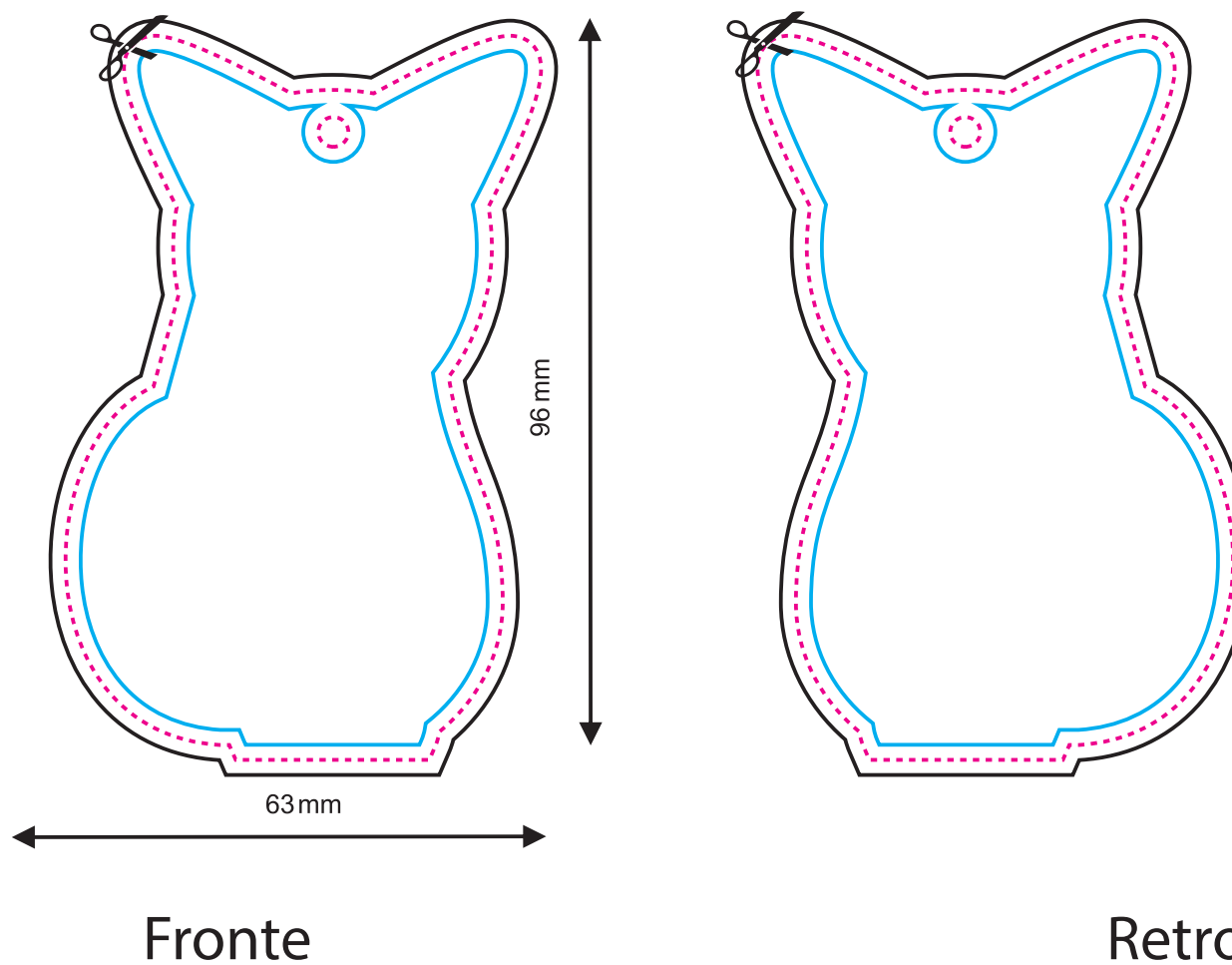

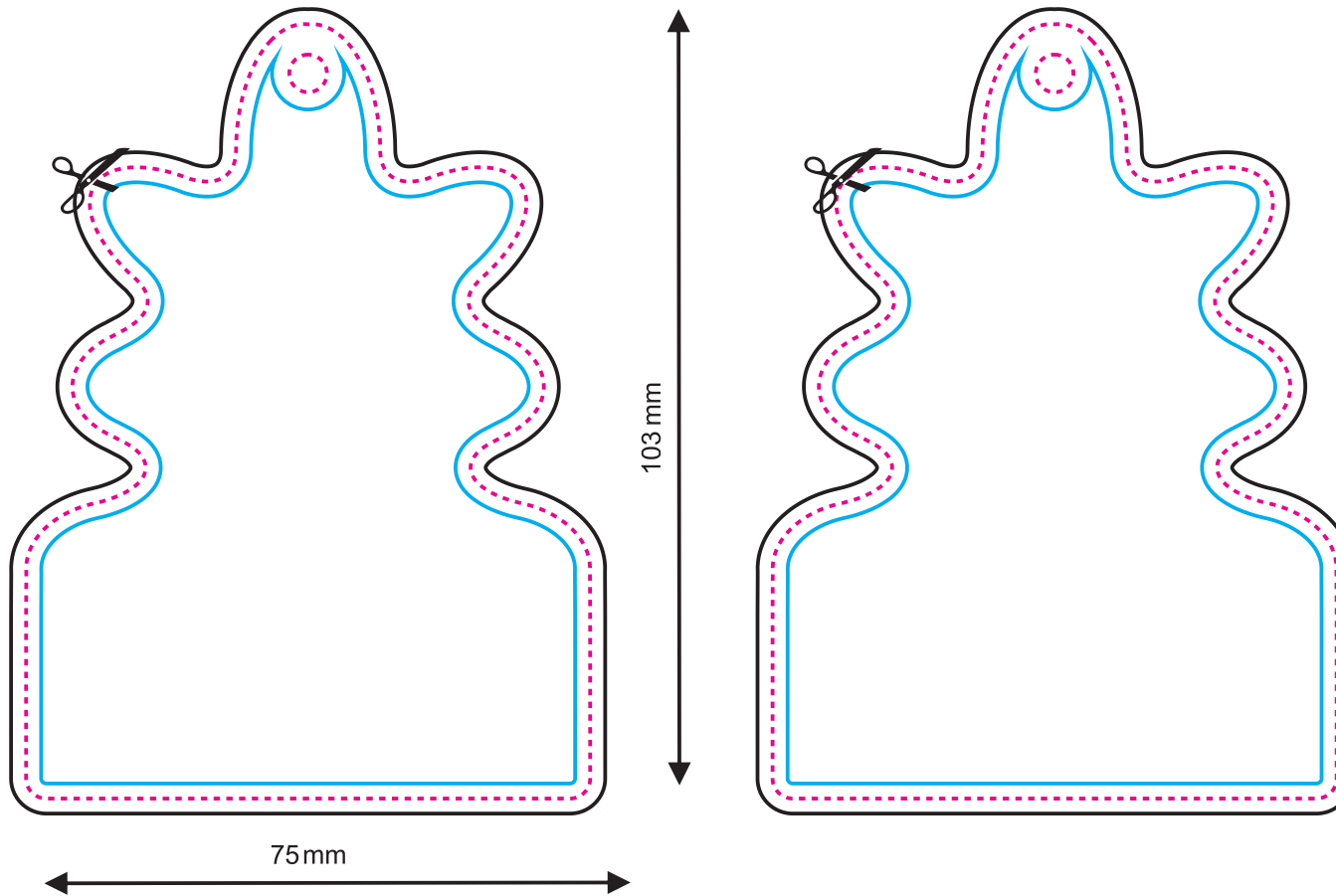
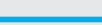
LINEA DEL TAGLIO PROGETTO CON ABBONDAGGIO LINEA DI SICUREZZA (tutti gli elementi importanti devono essere inseriti all'interno di questa linea) 

Fronte

Retro

LINEA DEL TAGLIO



PROGETTO CON ABBONDAGGIO



LINEA DI SICUREZZA (tutti gli elementi importanti devono essere inseriti all'interno di questa linea)

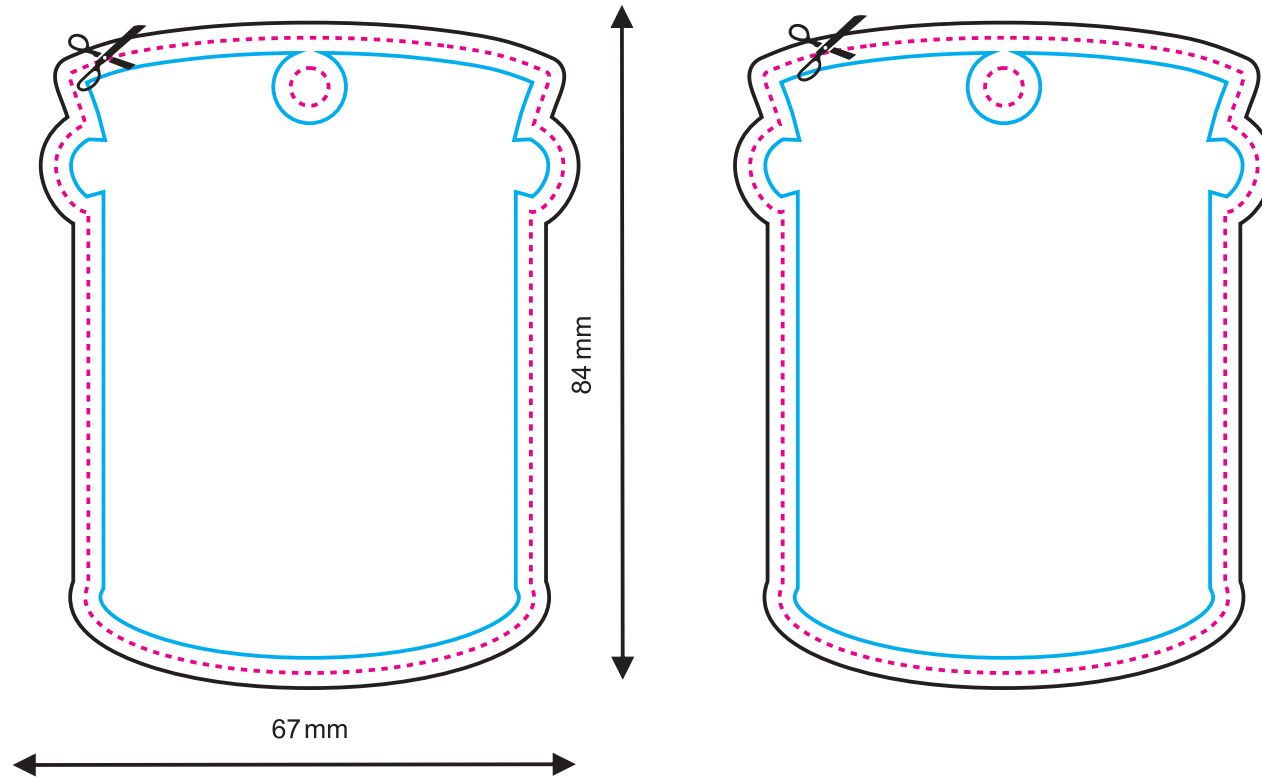

Fronte

Retro

LINEA DEL TAGLIO



PROGETTO CON ABBONDAGGIO

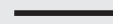

LINEA DI SICUREZZA (tutti gli elementi importanti devono essere inseriti all'interno di questa linea)

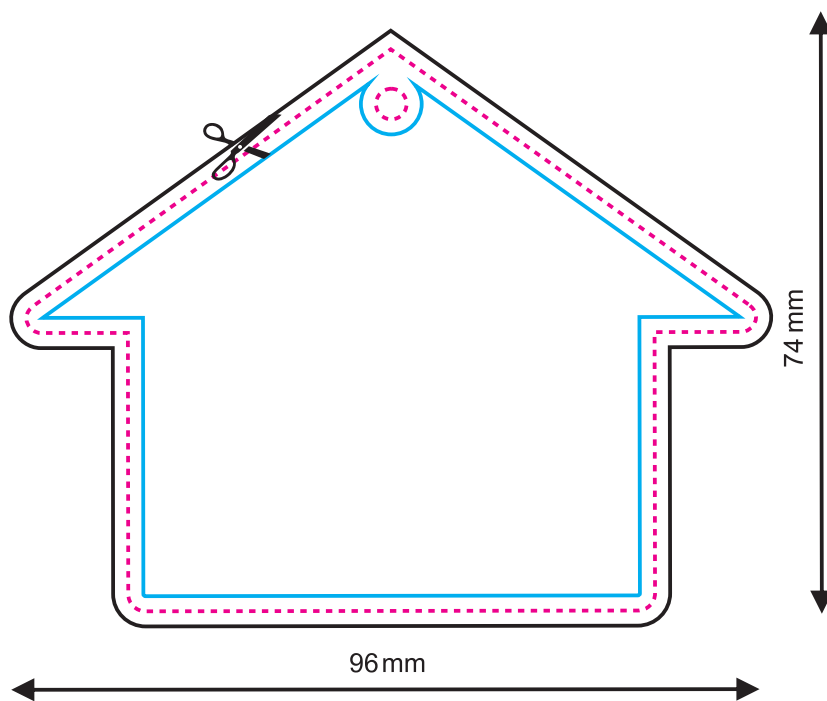
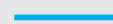

Fronte

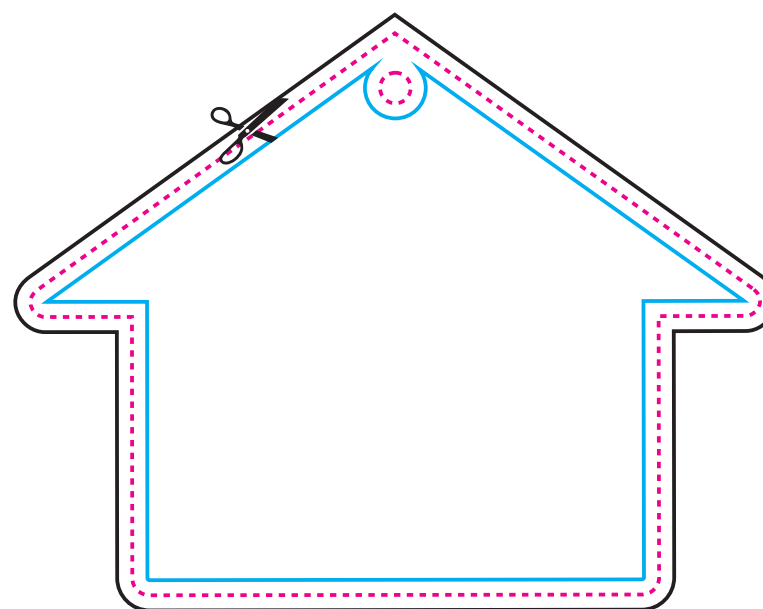

Retro

LINEA DEL TAGLIO



PROGETTO CON ABBONDAGGIO

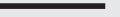

LINEA DI SICUREZZA (tutti gli elementi importanti devono essere inseriti all'interno di questa linea)

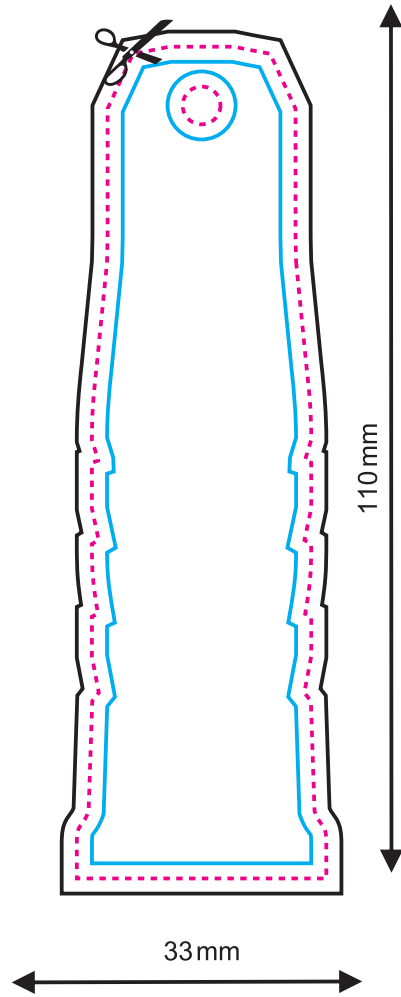
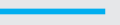

Fronte

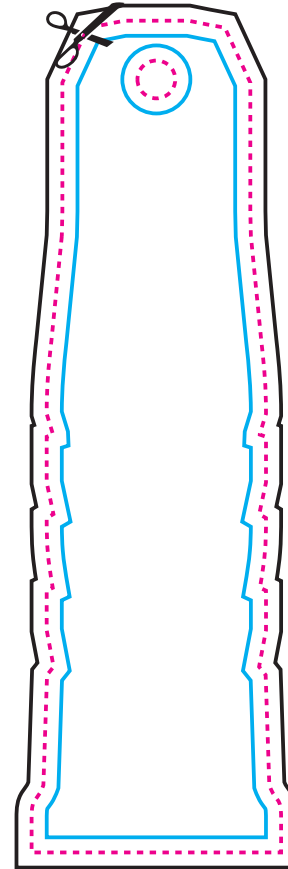

Retro

650

LEGENDA

LINEA DEL TAGLIO



PROGETTO CON ABBONDAGGIO

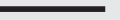

LINEA DI SICUREZZA (tutti gli elementi importanti devono essere inseriti all'interno di questa linea)

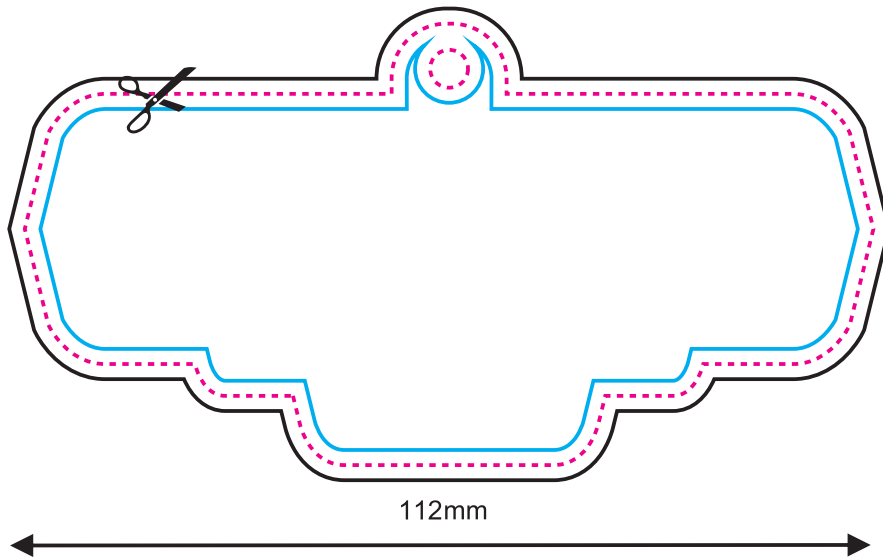

Fronte

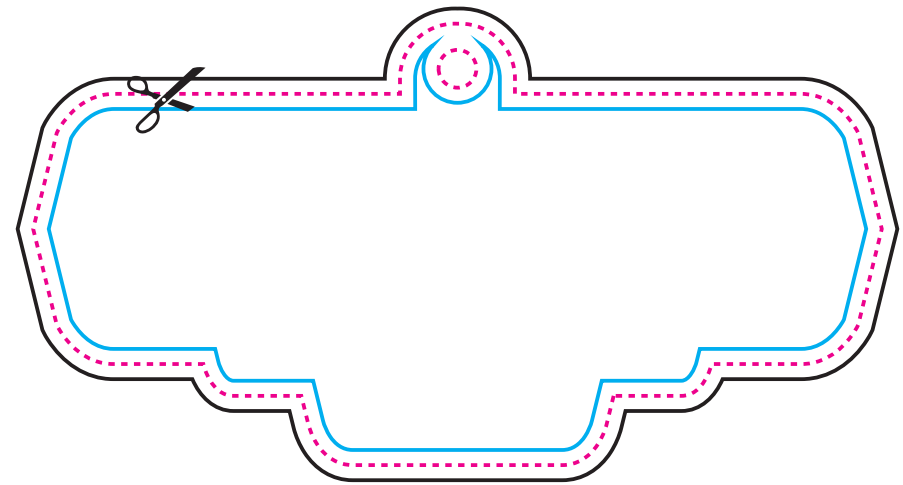

Retro

651

LEGENDA

LINEA DEL TAGLIO



PROGETTO CON ABBONDAGGIO



LINEA DI SICUREZZA (tutti gli elementi importanti devono essere inseriti all'interno di questa linea)

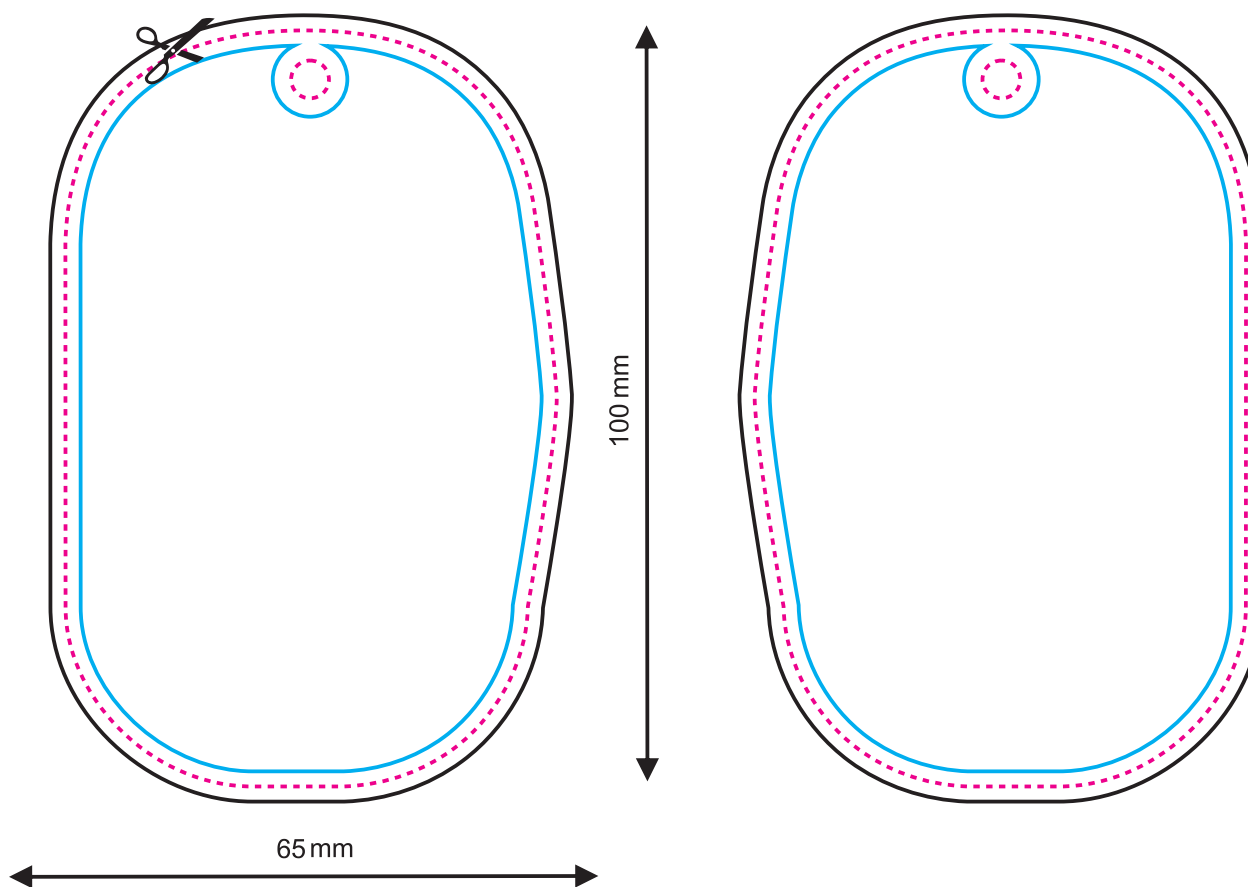
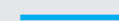

Fronte

Retro



LINEA DEL TAGLIO



PROGETTO CON ABBONDAGGIO

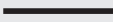

LINEA DI SICUREZZA (tutti gli elementi importanti devono essere inseriti all'interno di questa linea)

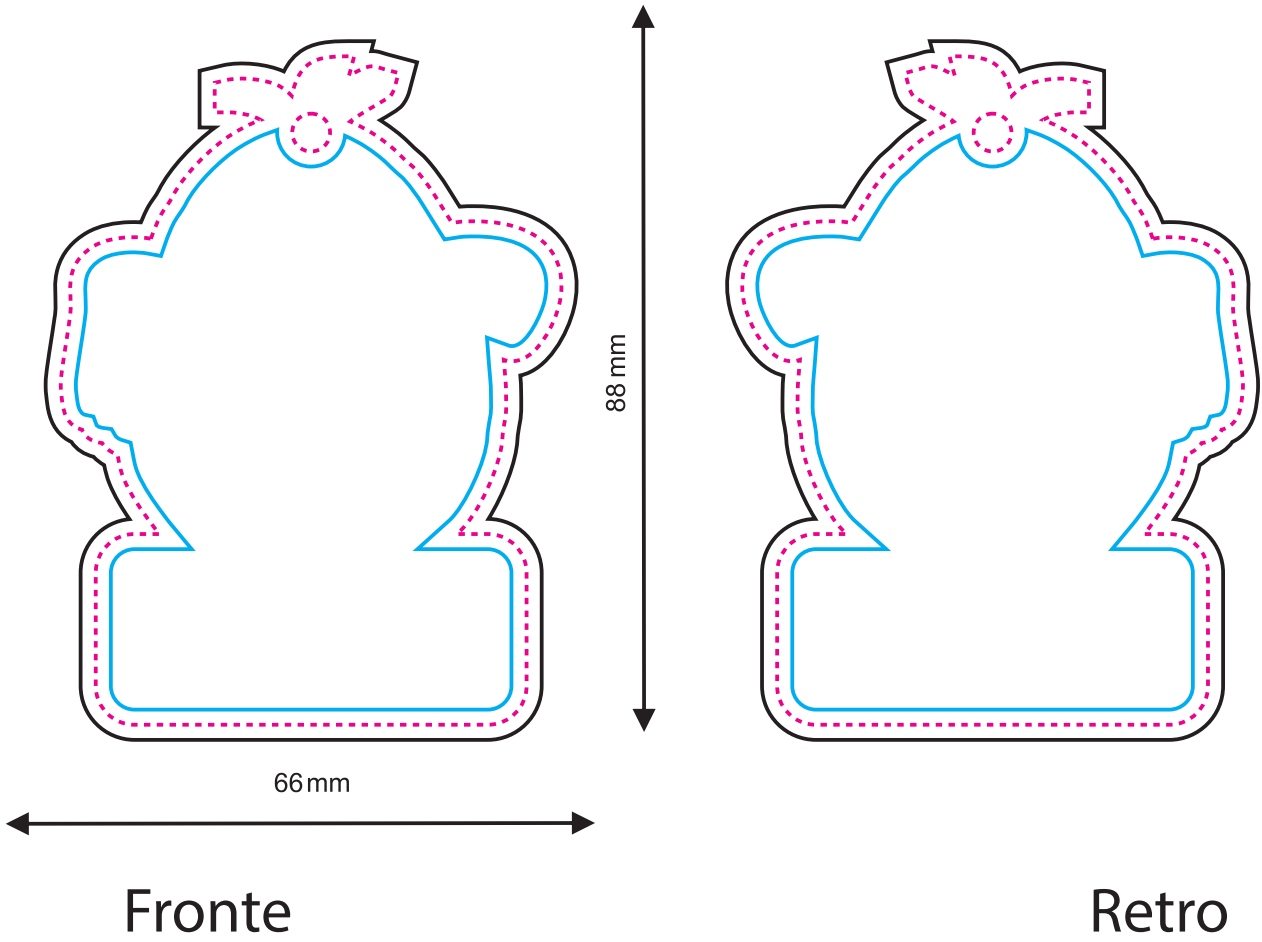
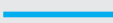

LINEA DEL TAGLIO



PROGETTO CON ABBONDAGGIO

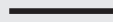

LINEA DI SICUREZZA (tutti gli elementi importanti devono essere inseriti all'interno di questa linea)

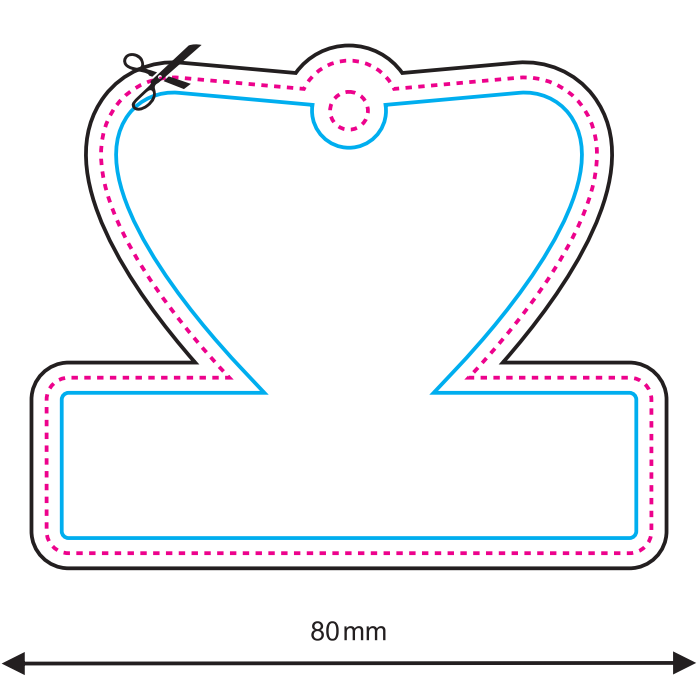

Fronte

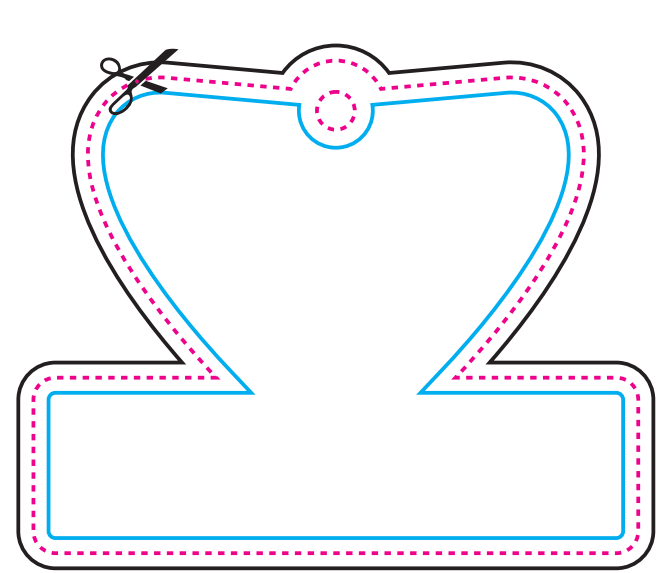

Retro

LINEA DEL TAGLIO



PROGETTO CON ABBONDAGGIO



LINEA DI SICUREZZA (tutti gli elementi importanti devono essere inseriti all'interno di questa linea)

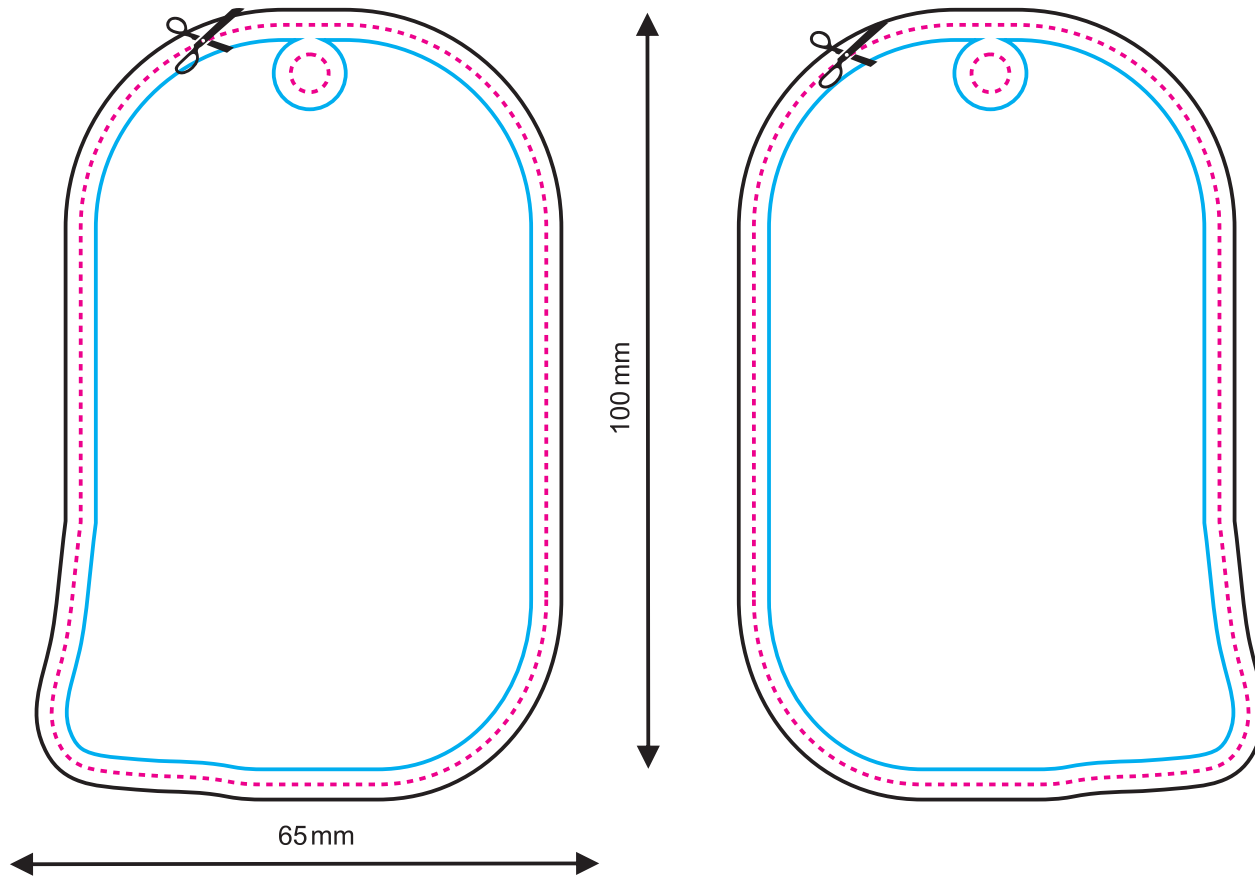

Fronte

Retro

653

LEGENDA

LINEA DEL TAGLIO



PROGETTO CON ABBONDAGGIO

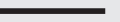

LINEA DI SICUREZZA (tutti gli elementi importanti devono essere inseriti all'interno di questa linea)

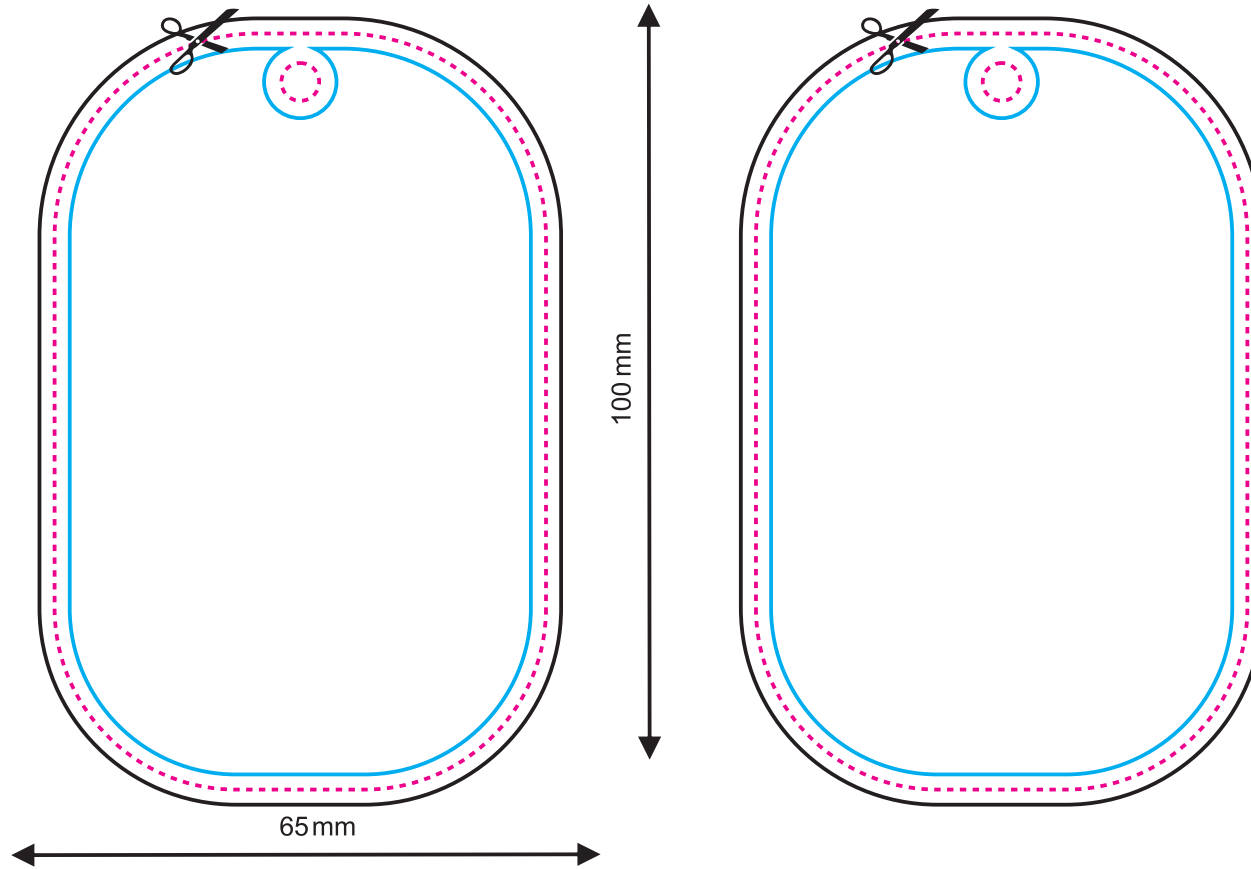
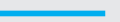

Fronte

Retro

LINEA DEL TAGLIO



PROGETTO CON ABBONDAGGIO

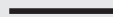

LINEA DI SICUREZZA (tutti gli elementi importanti devono essere inseriti all'interno di questa linea)

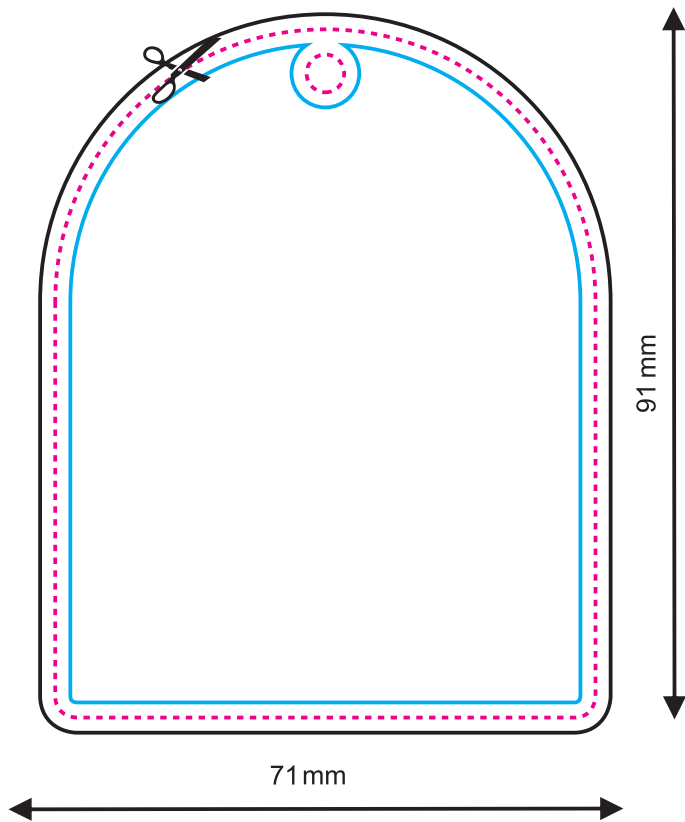

Fronte

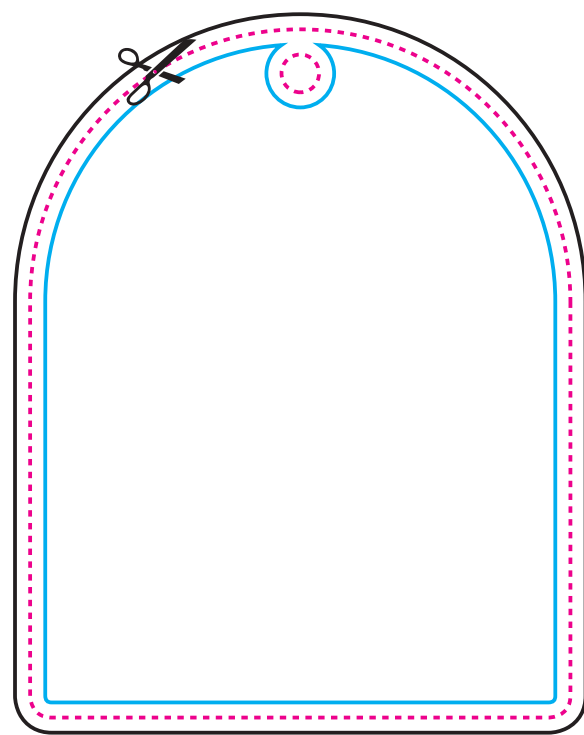

Retro

669

LEGENDA

LINEA DEL TAGLIO



PROGETTO CON ABBONDAGGIO

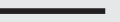

LINEA DI SICUREZZA (tutti gli elementi importanti devono essere inseriti all'interno di questa linea)

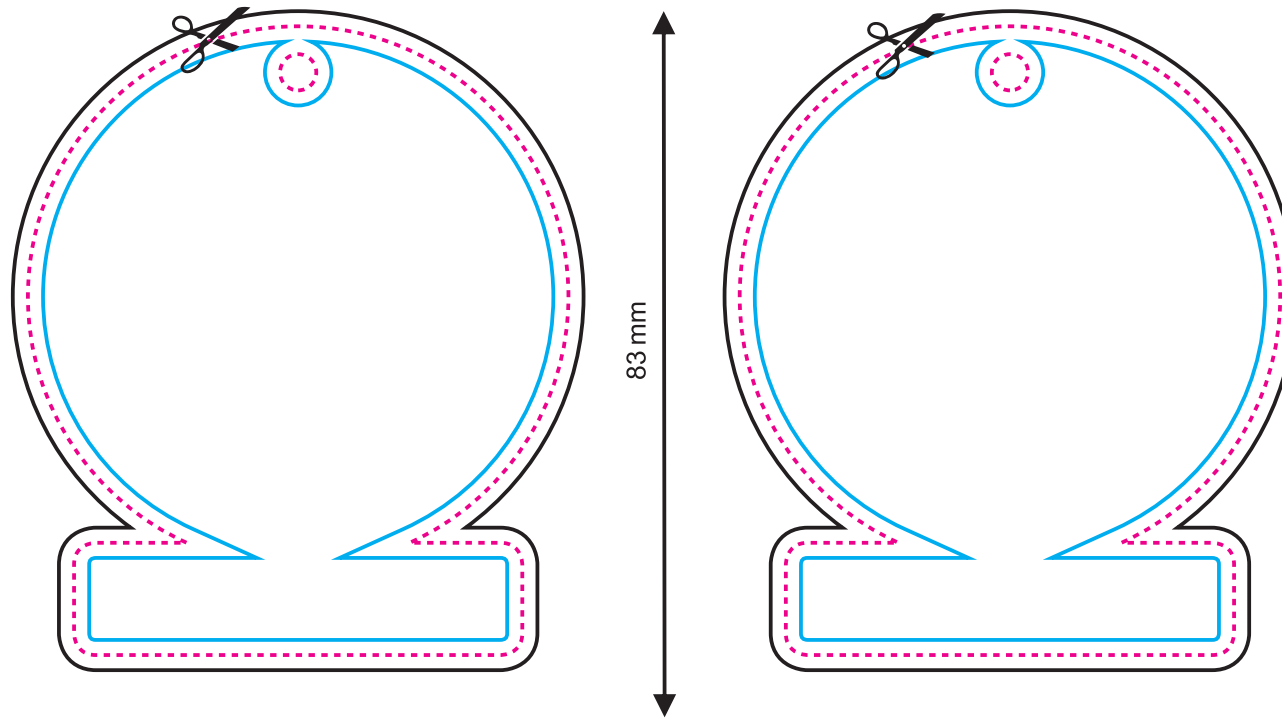

Fronte

Retro

LINEA DEL TAGLIO



PROGETTO CON ABBONDAGGIO

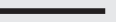

LINEA DI SICUREZZA (tutti gli elementi importanti devono essere inseriti all'interno di questa linea)

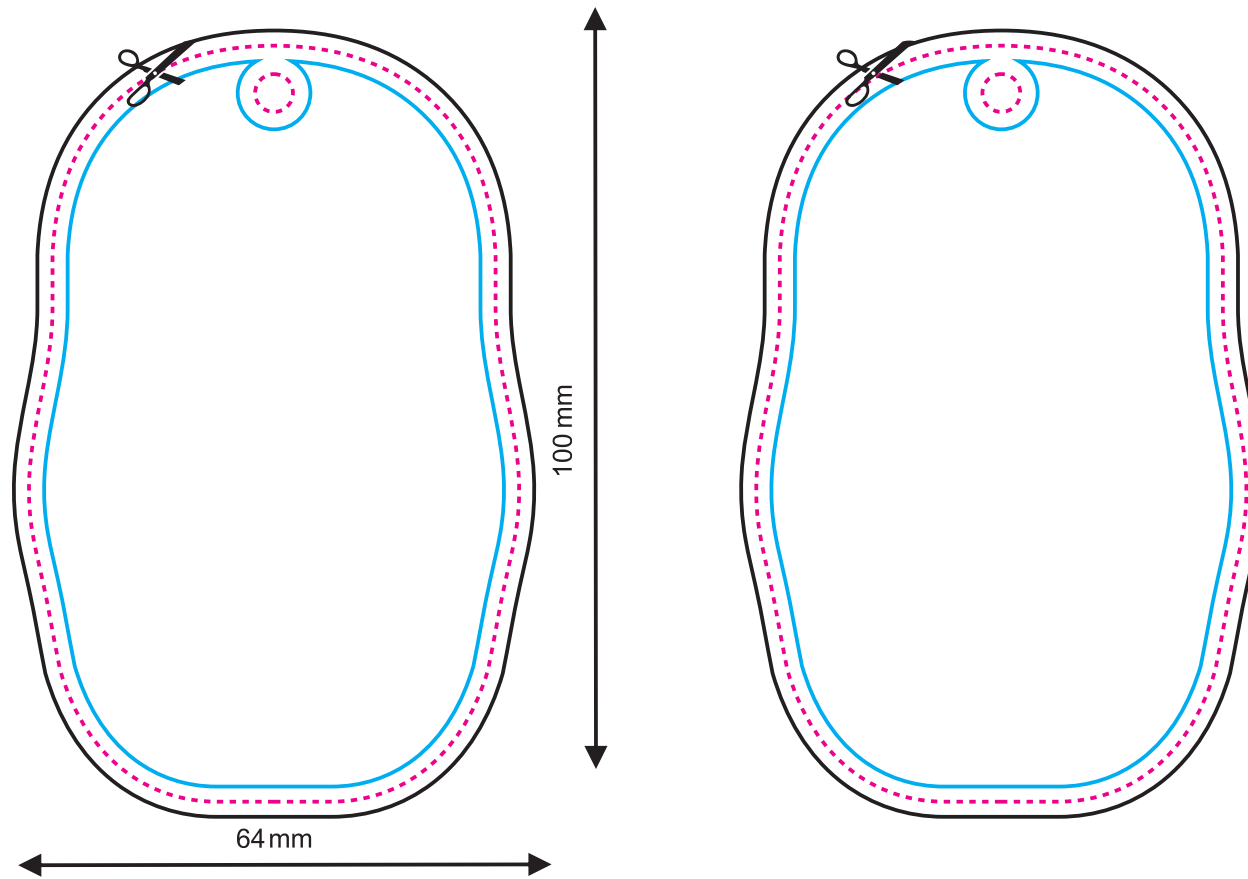
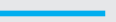

Fronte

Retro

LINEA DEL TAGLIO



PROGETTO CON ABBONDAGGIO

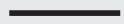

LINEA DI SICUREZZA (tutti gli elementi importanti devono essere inseriti all'interno di questa linea)



Fronte

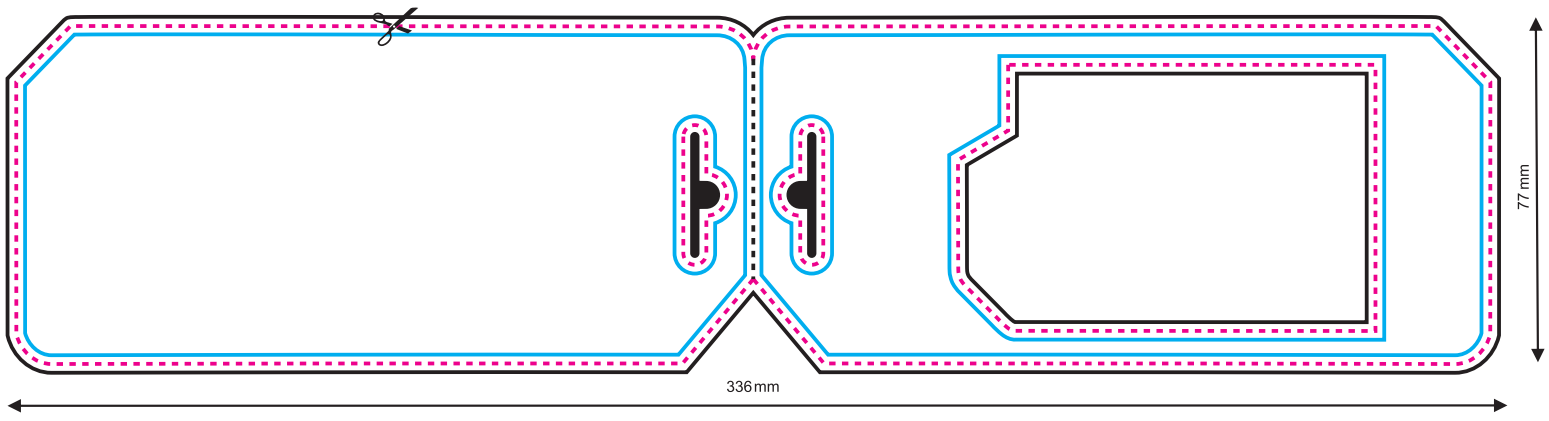

Retro

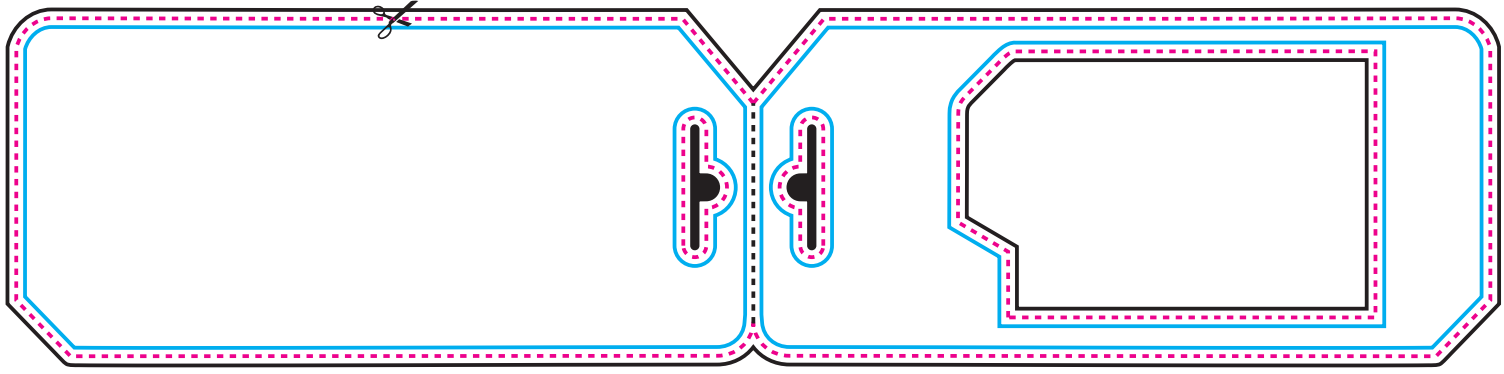



LINEA DEL TAGLIO



PROGETTO CON ABBONDAGGIO



LINEA DI SICUREZZA (tutti gli elementi importanti devono essere inseriti all'interno di questa linea)

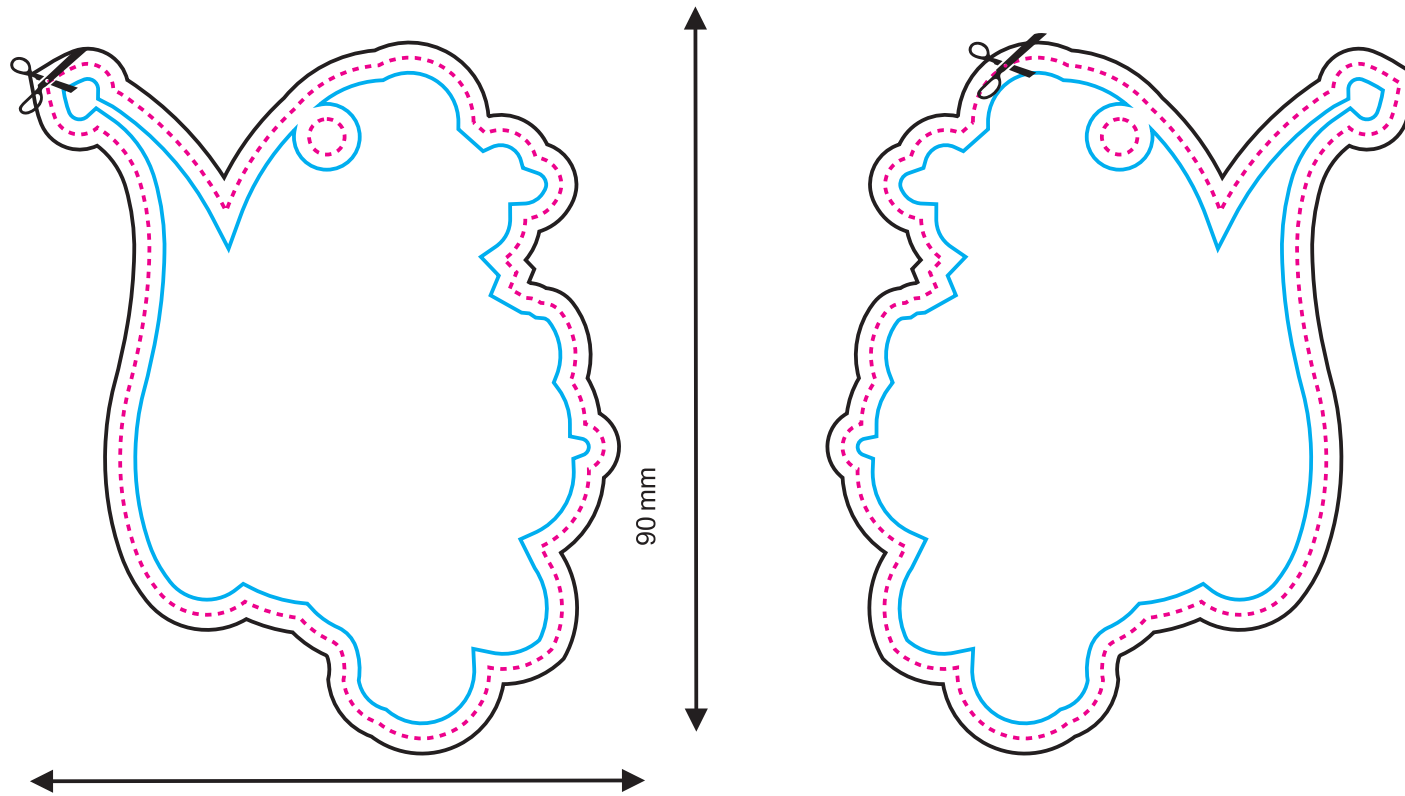
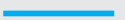

Fronte

Retro

656

LEGENDA

LINEA DEL TAGLIO



PROGETTO CON ABBONDAGGIO

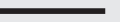

LINEA DI SICUREZZA (tutti gli elementi importanti devono essere inseriti all'interno di questa linea)

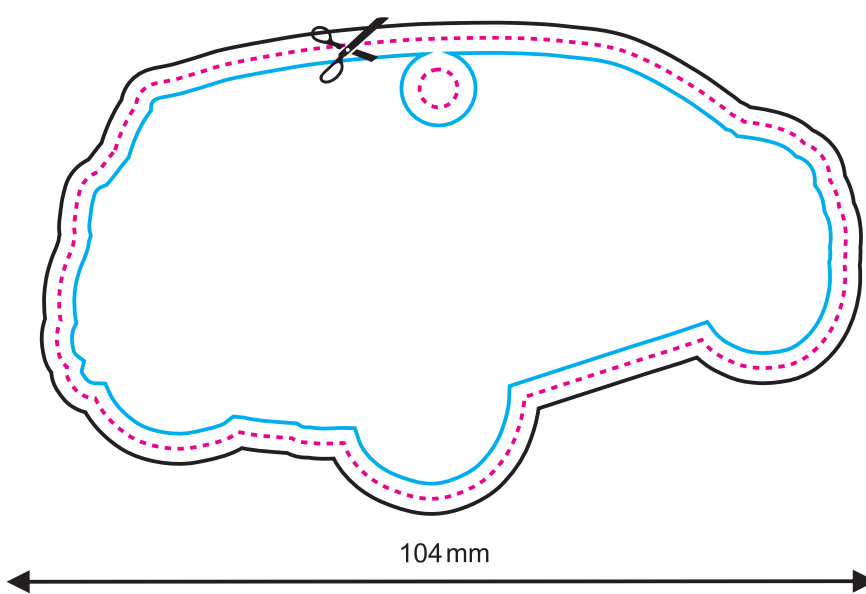
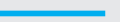

Fronte

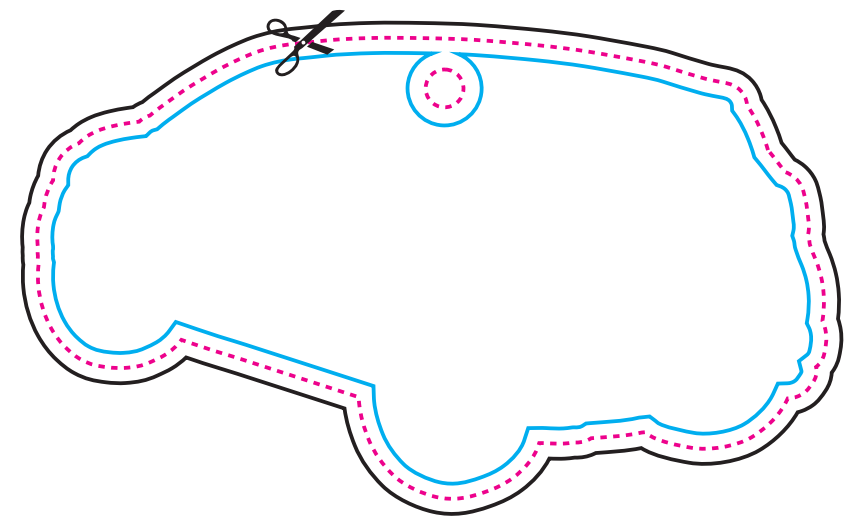

Retro

LINEA DEL TAGLIO



PROGETTO CON ABBONDAGGIO



LINEA DI SICUREZZA (tutti gli elementi importanti devono essere inseriti all'interno di questa linea)

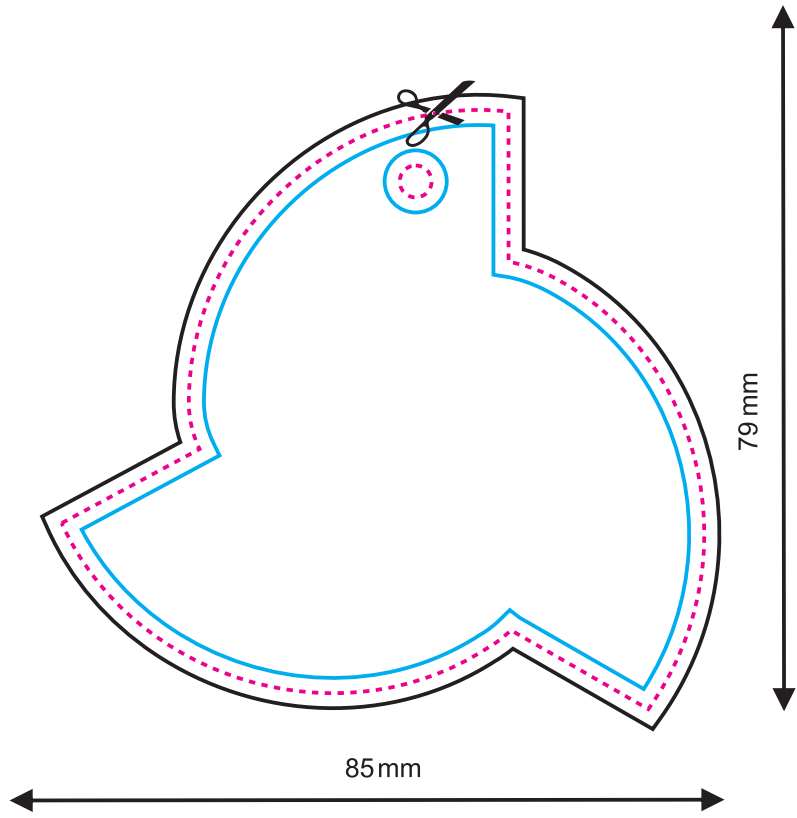

Fronte

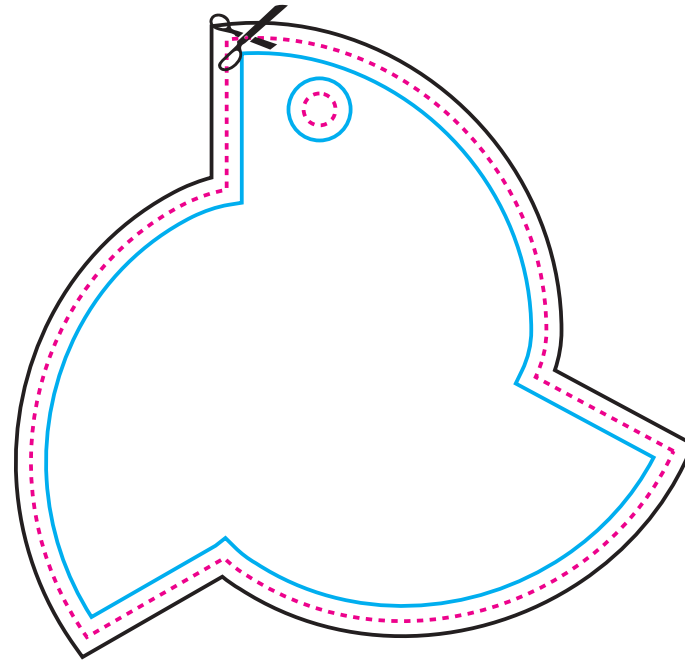

Retro

672

LEGENDA

LINEA DEL TAGLIO



PROGETTO CON ABBONDAGGIO

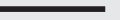

LINEA DI SICUREZZA (tutti gli elementi importanti devono essere inseriti all'interno di questa linea)

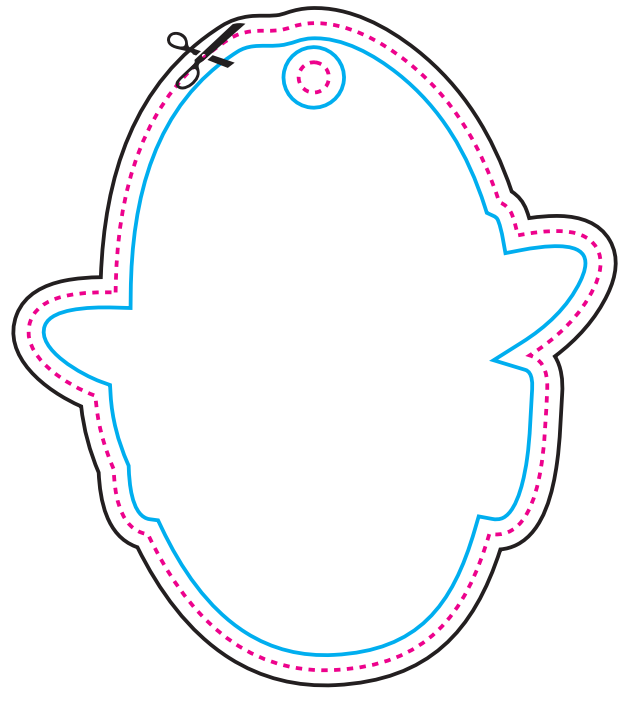
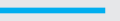

85 mm

75mm

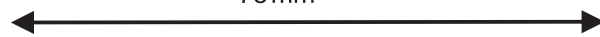

Fronte

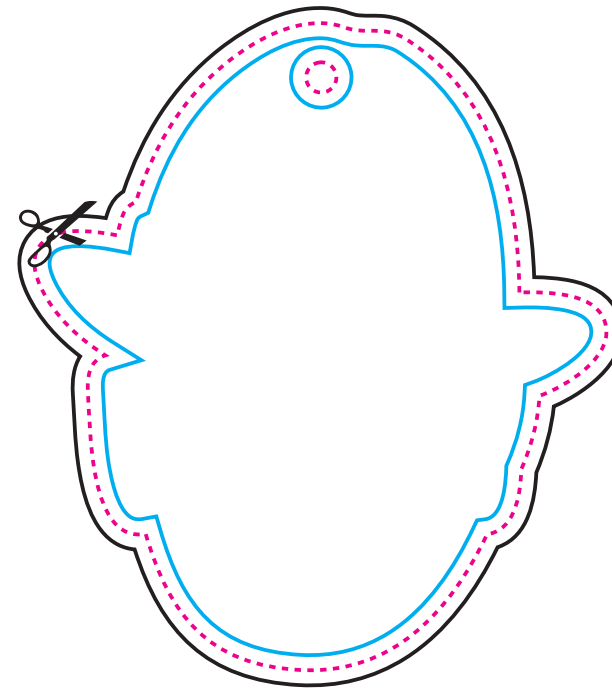

Retro

LINEA DEL TAGLIO



PROGETTO CON ABBONDAGGIO

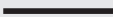

LINEA DI SICUREZZA (tutti gli elementi importanti devono essere inseriti all'interno di questa linea)

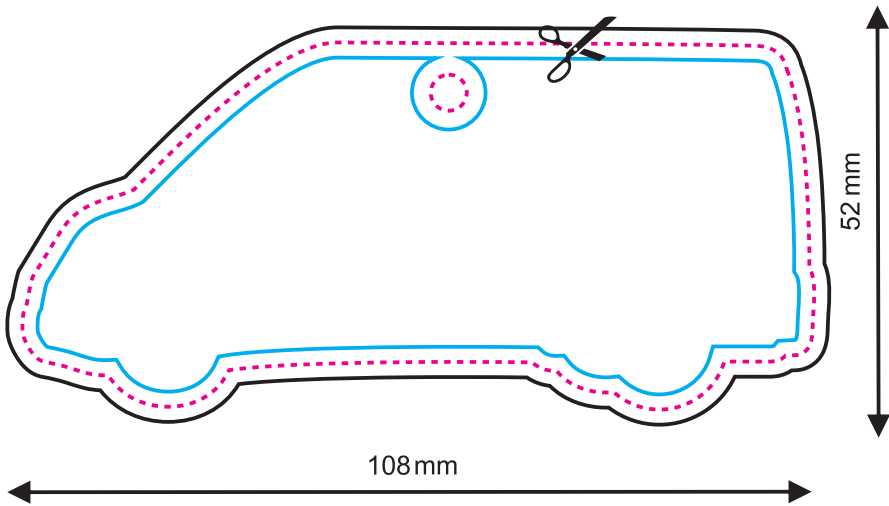

Fronte

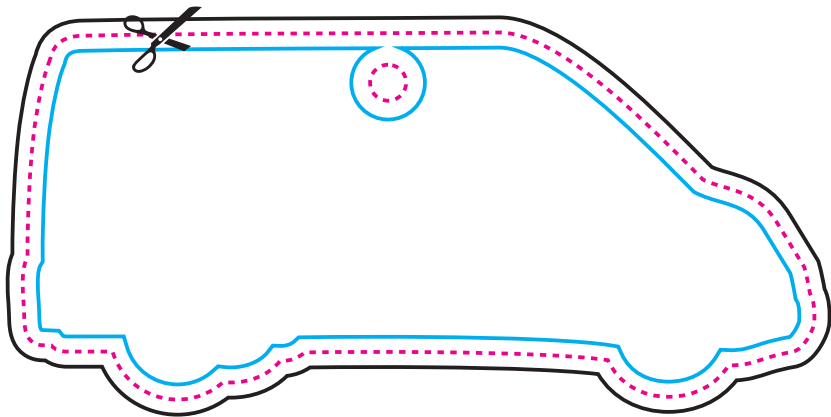

Retro

LINEA DEL TAGLIO



PROGETTO CON ABBONDAGGIO

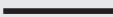

LINEA DI SICUREZZA (tutti gli elementi importanti devono essere inseriti all'interno di questa linea)

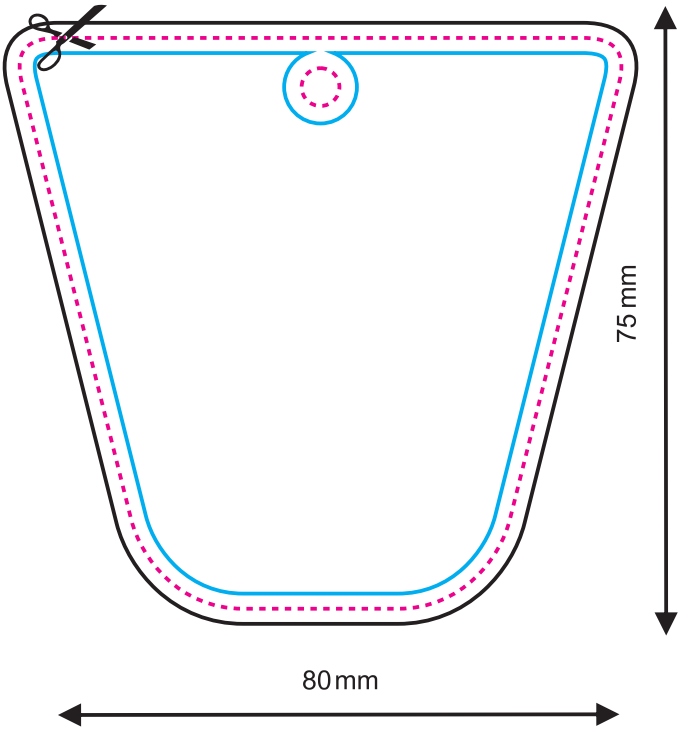

Fronte

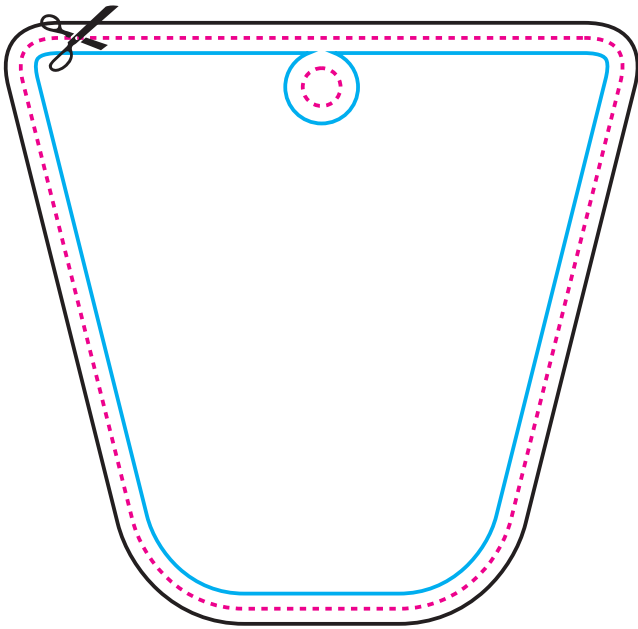

Retro

LINEA DEL TAGLIO



PROGETTO CON ABBONDAGGIO

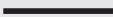

LINEA DI SICUREZZA (tutti gli elementi importanti devono essere inseriti all'interno di questa linea)

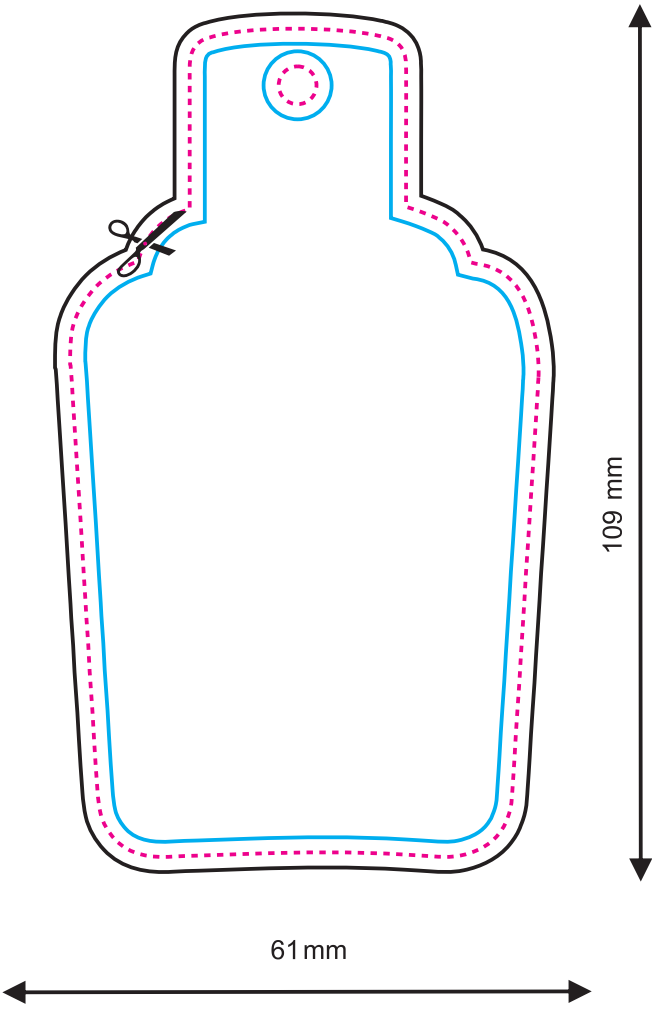

Fronte

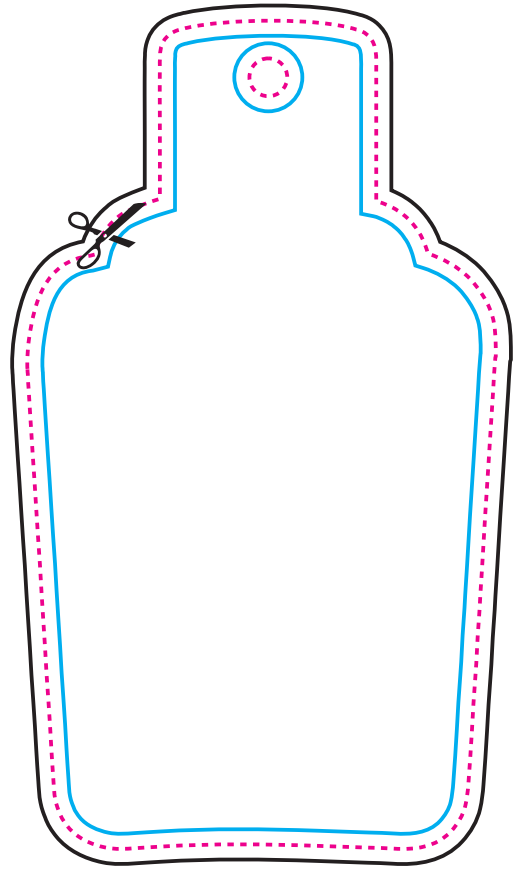

Retro

659

LEGENDA

LINEA DEL TAGLIO



PROGETTO CON ABBONDAGGIO



LINEA DI SICUREZZA (tutti gli elementi importanti devono essere inseriti all'interno di questa linea)

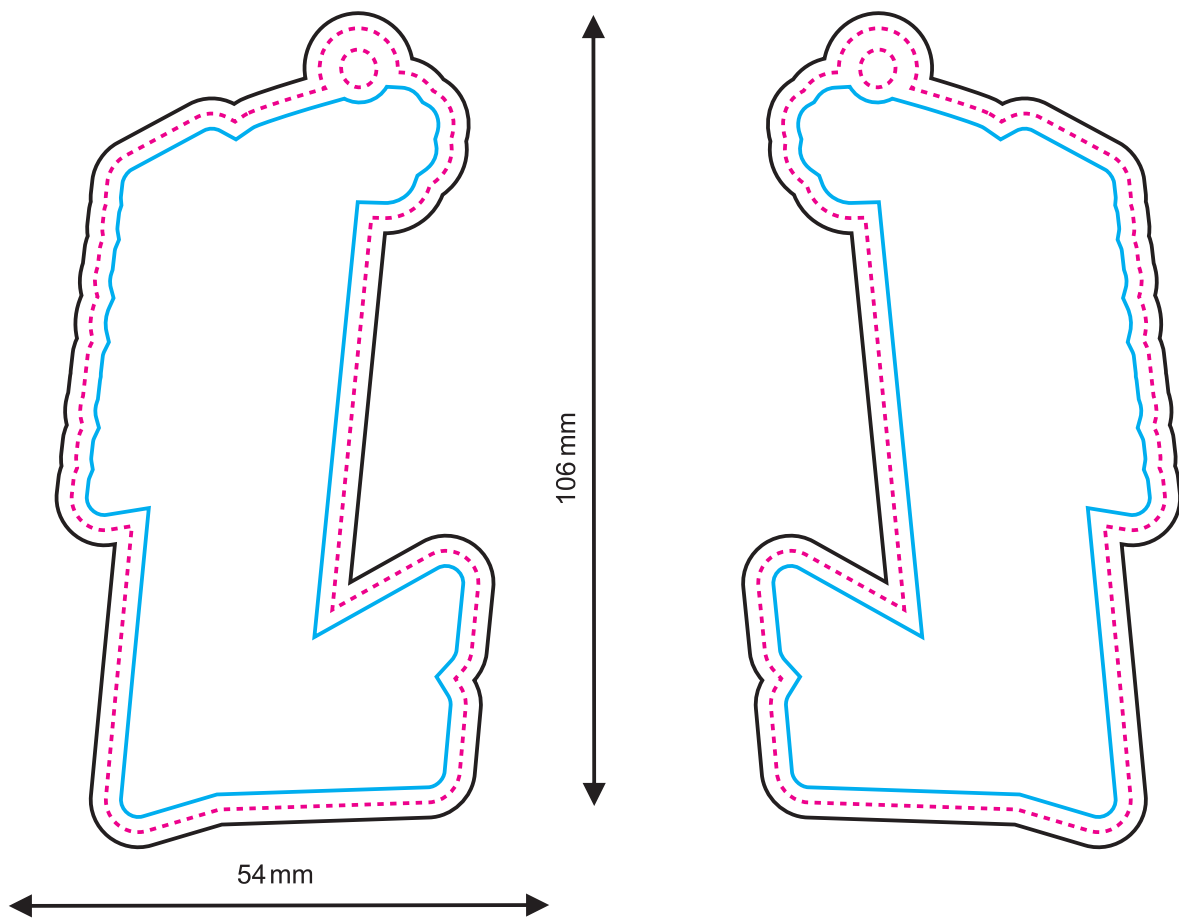
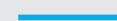

Fronte

Retro



LINEA DEL TAGLIO



PROGETTO CON ABBONDAGGIO

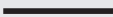

LINEA DI SICUREZZA (tutti gli elementi importanti devono essere inseriti all'interno di questa linea)

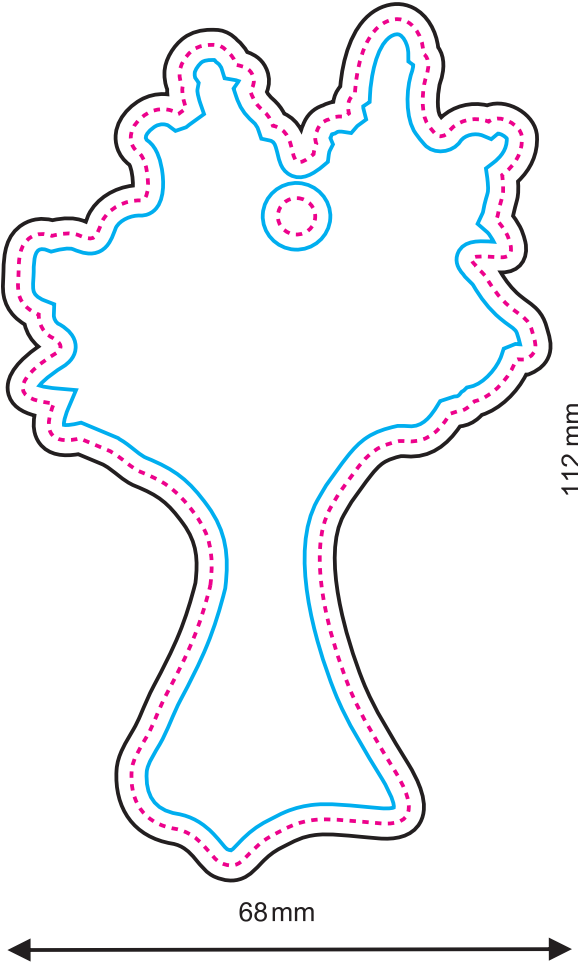

Fronte

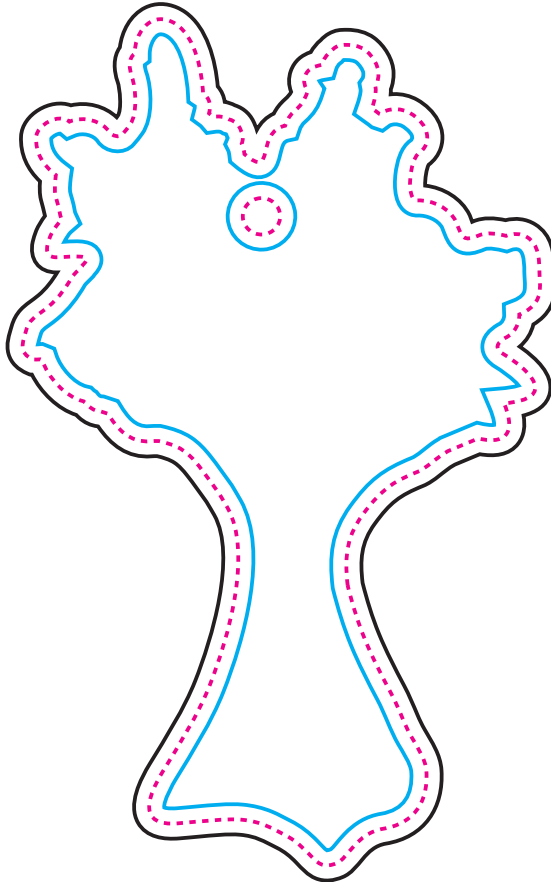

Retro

LINEA DEL TAGLIO



PROGETTO CON ABBONDAGGIO

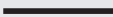

LINEA DI SICUREZZA (tutti gli elementi importanti devono essere inseriti all'interno di questa linea)

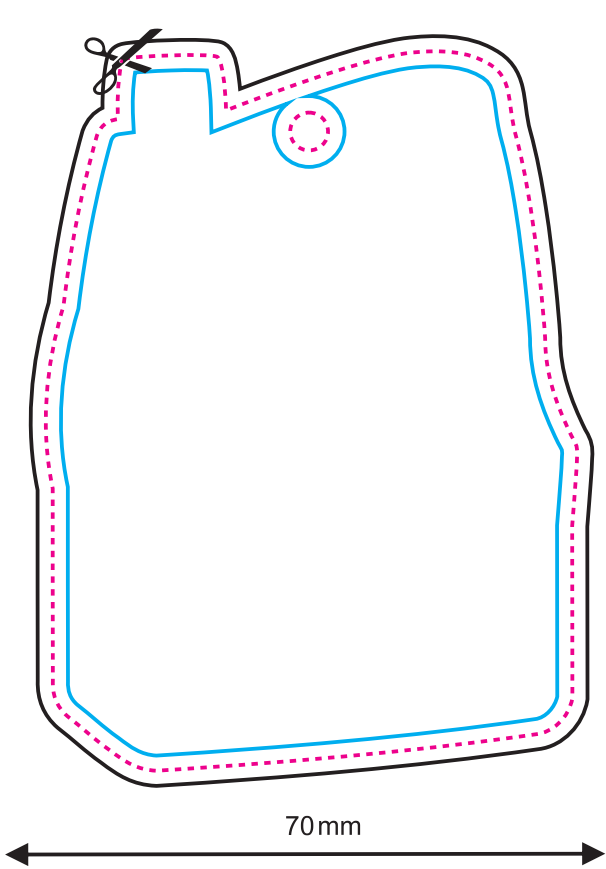

Fronte

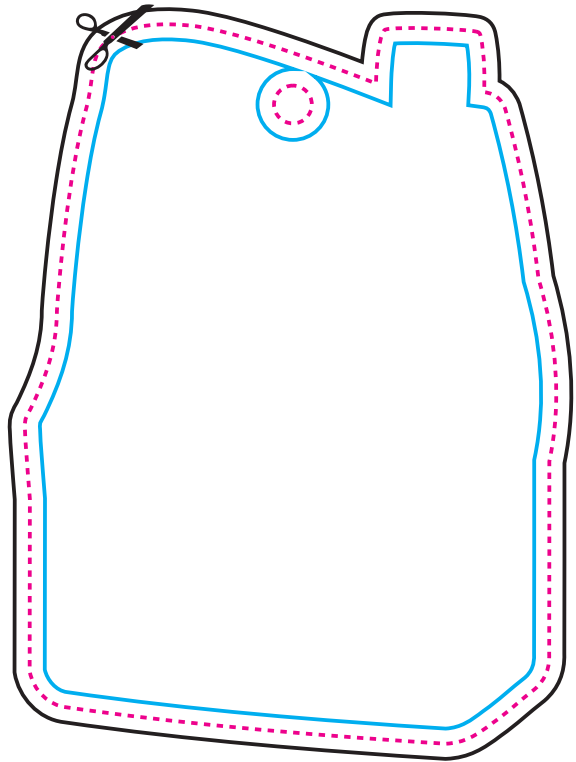

Retro

LINEA DEL TAGLIO



PROGETTO CON ABBONDAGGIO

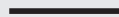

LINEA DI SICUREZZA (tutti gli elementi importanti devono essere inseriti all'interno di questa linea)

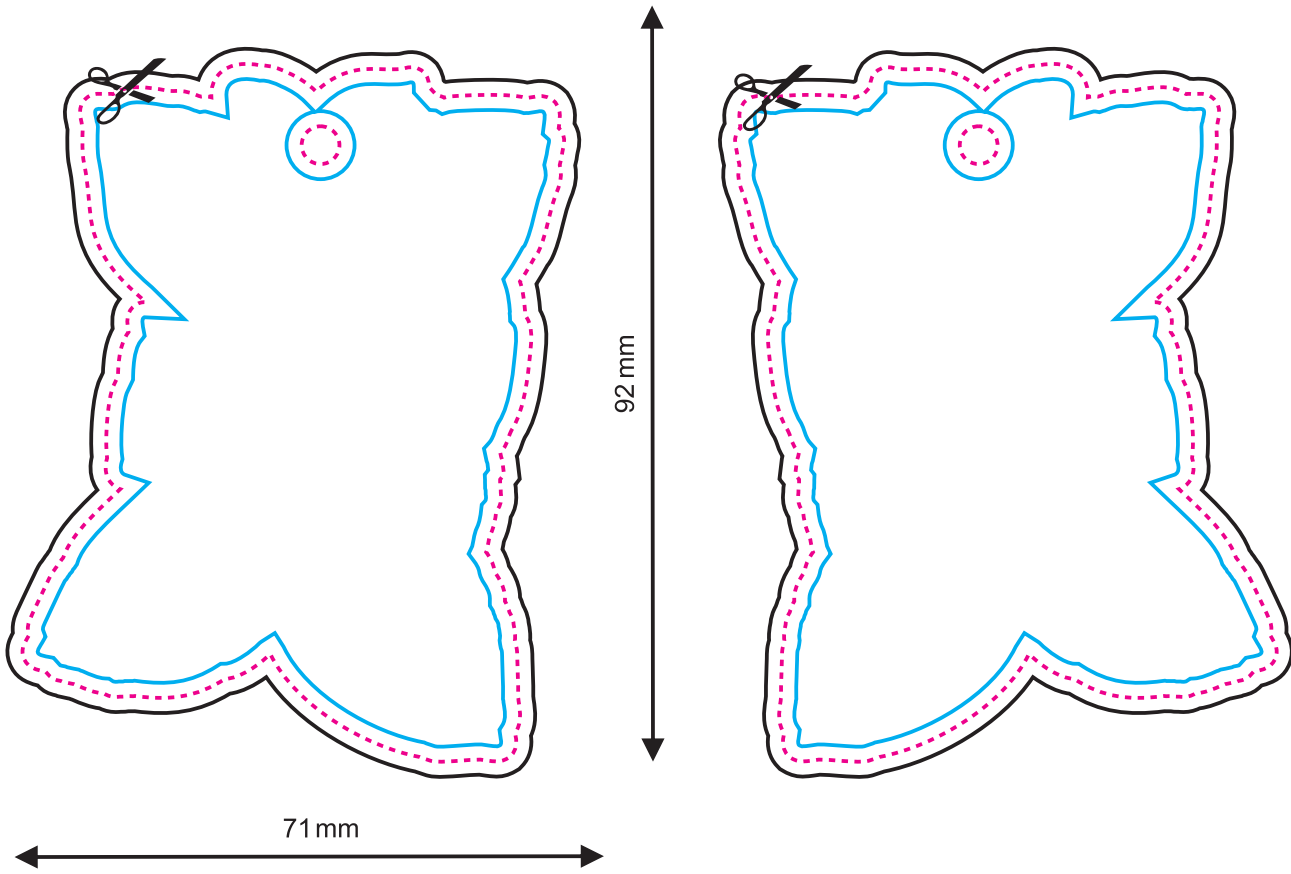

Fronte

Retro

LINEA DEL TAGLIO



PROGETTO CON ABBONDAGGIO

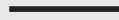

LINEA DI SICUREZZA (tutti gli elementi importanti devono essere inseriti all'interno di questa linea)

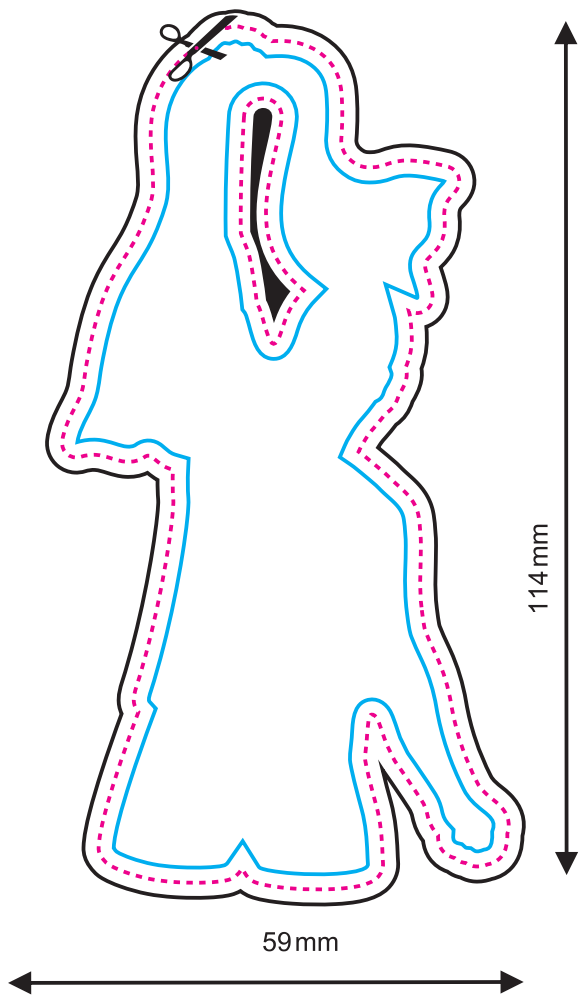

Fronte

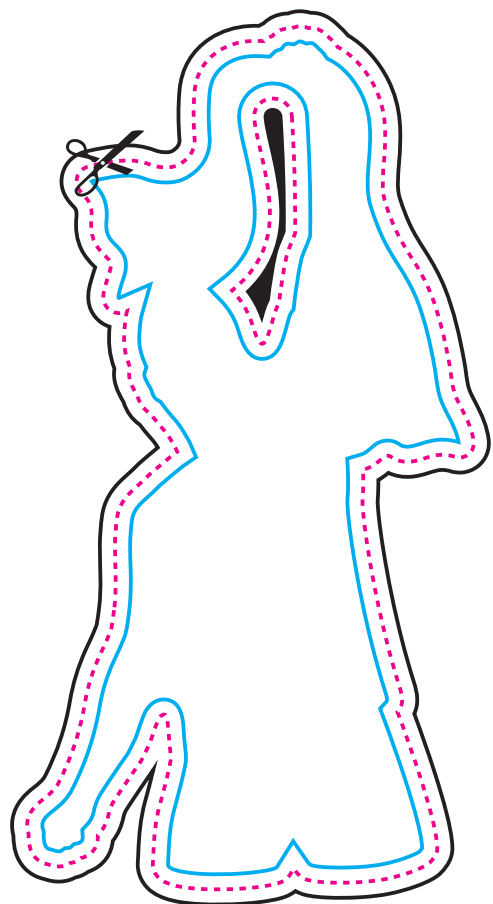

Retro

689

LEGENDA

LINEA DEL TAGLIO



PROGETTO CON ABBONDAGGIO

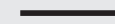

LINEA DI SICUREZZA (tutti gli elementi importanti devono essere inseriti all'interno di questa linea)

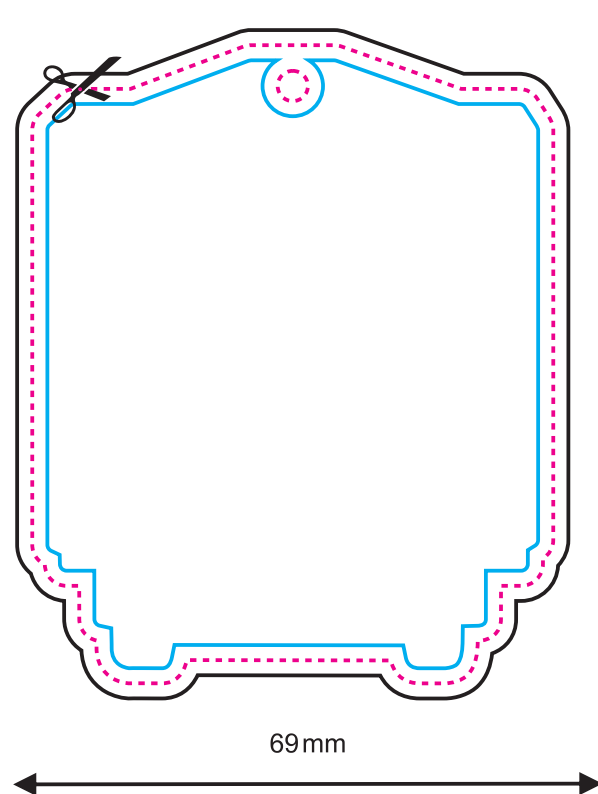
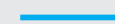

Fronte

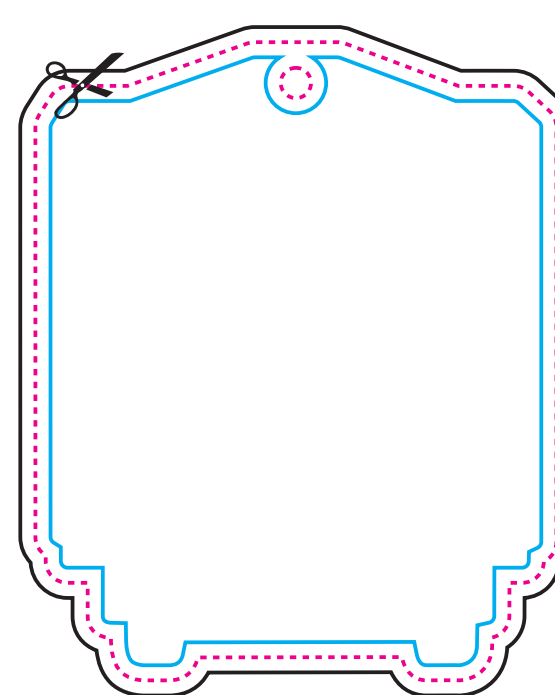

Retro

688

LEGENDA

LINEA DEL TAGLIO



PROGETTO CON ABBONDAGGIO

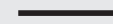

LINEA DI SICUREZZA (tutti gli elementi importanti devono essere inseriti all'interno di questa linea)

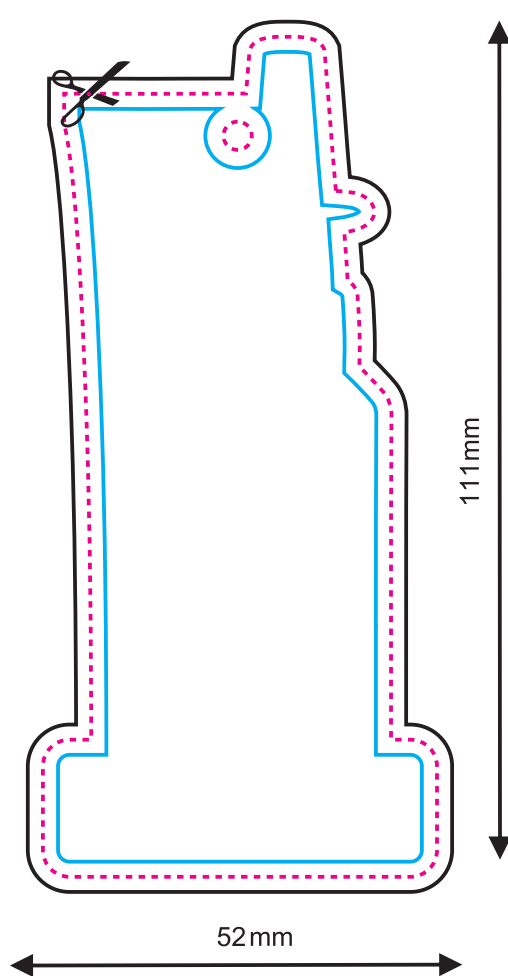
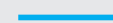

Fronte

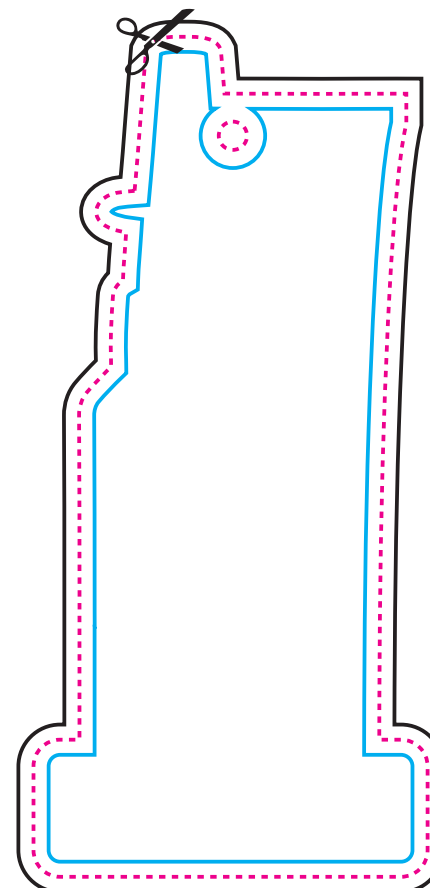

Retro

LINEA DEL TAGLIO



PROGETTO CON ABBONDAGGIO

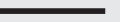

LINEA DI SICUREZZA (tutti gli elementi importanti devono essere inseriti all'interno di questa linea)

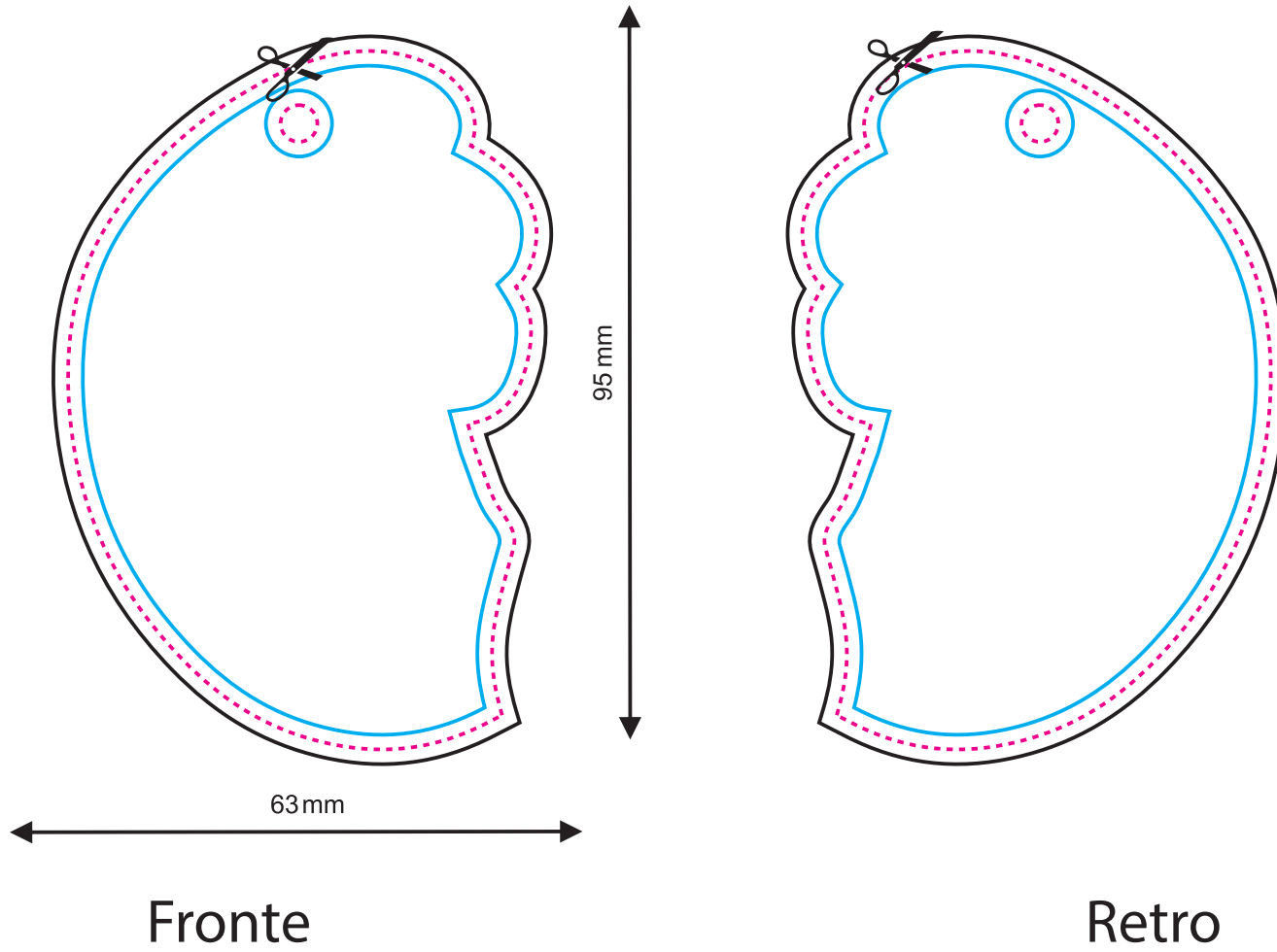
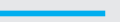

677

LEGENDA

LINEA DEL TAGLIO



PROGETTO CON ABBONDAGGIO

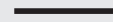

LINEA DI SICUREZZA (tutti gli elementi importanti devono essere inseriti all'interno di questa linea)

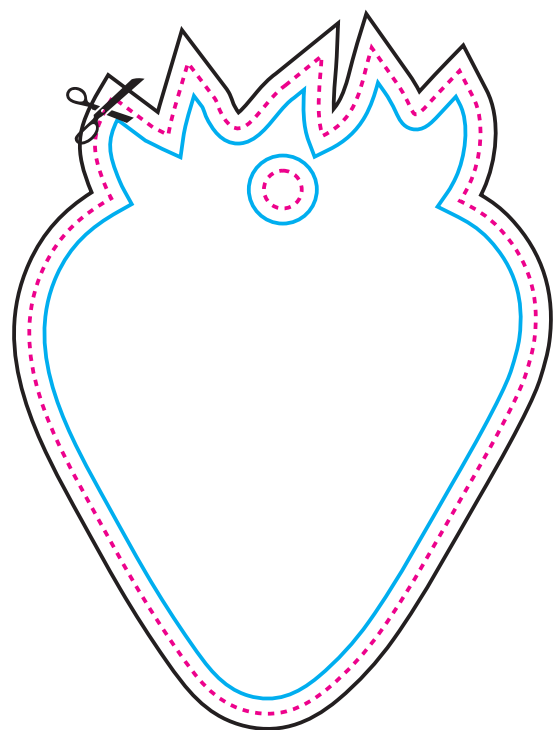
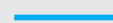

Fronte

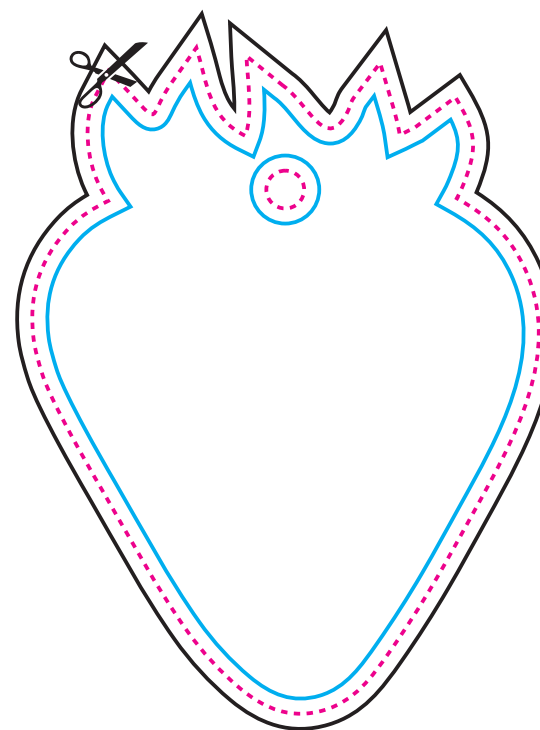

Retro



678

LEGENDA

LINEA DEL TAGLIO



PROGETTO CON ABBONDAGGIO



LINEA DI SICUREZZA (tutti gli elementi importanti devono essere inseriti all'interno di questa linea)

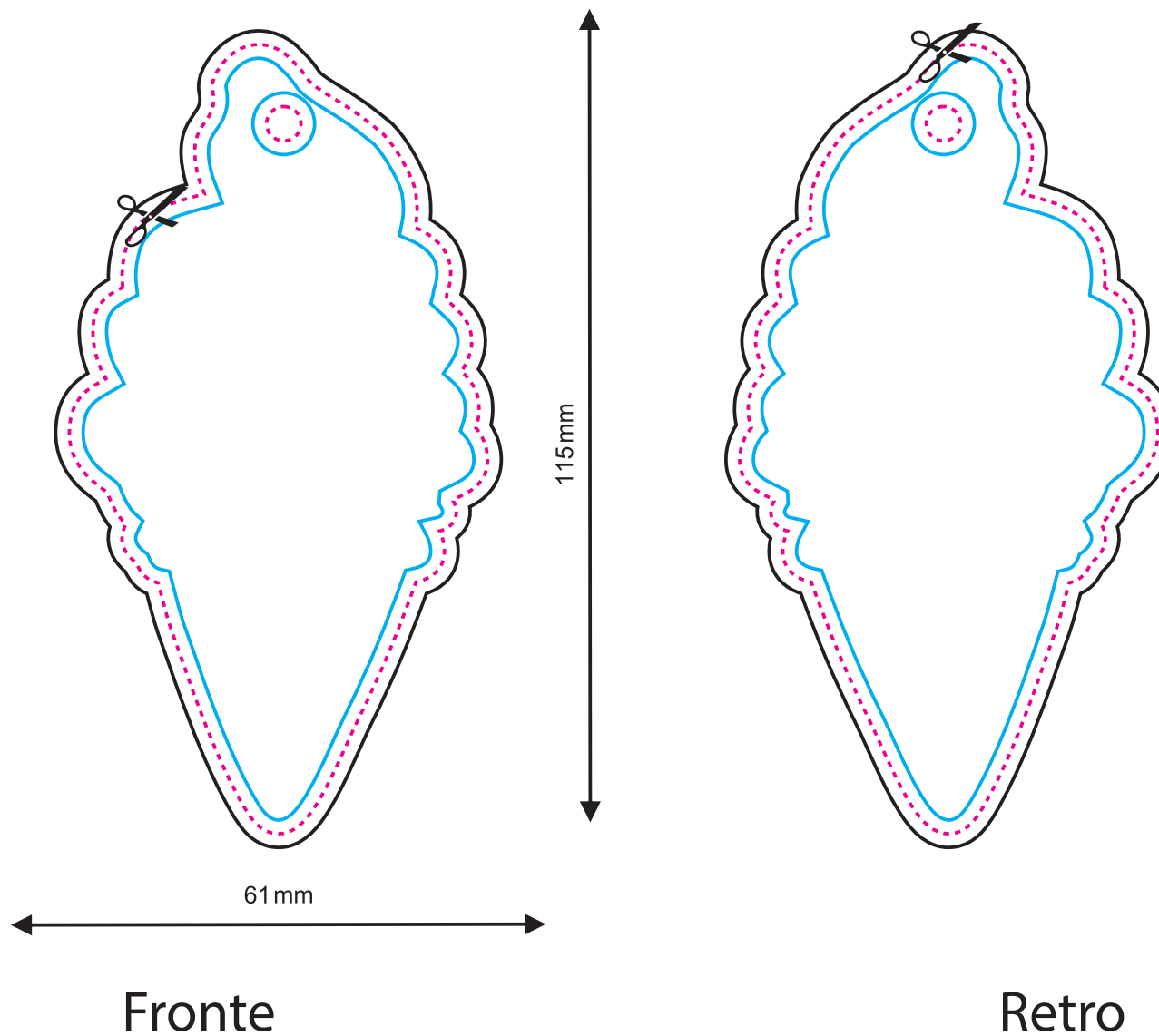

679

LEGENDA

LINEA DEL TAGLIO



PROGETTO CON ABBONDAGGIO

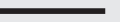

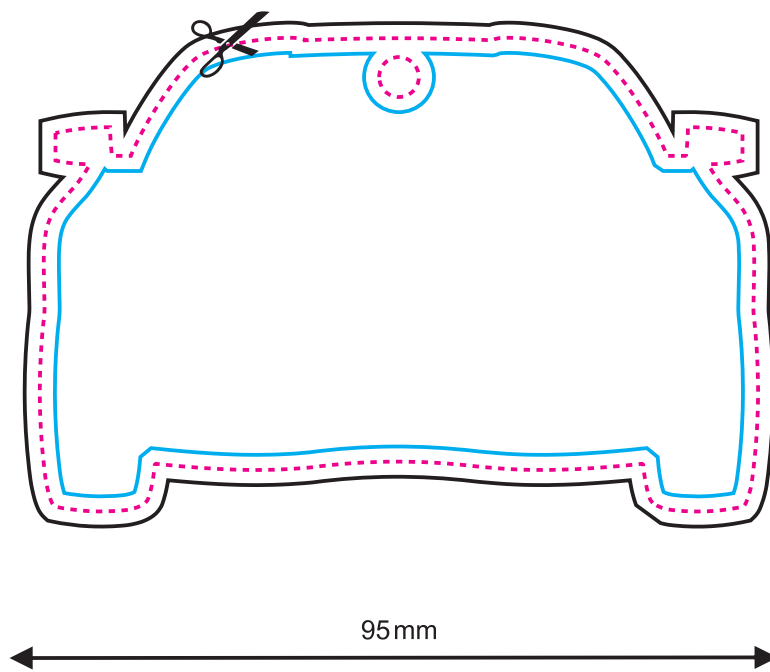
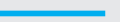

LINEA DI SICUREZZA (tutti gli elementi importanti devono essere inseriti all'interno di questa linea)

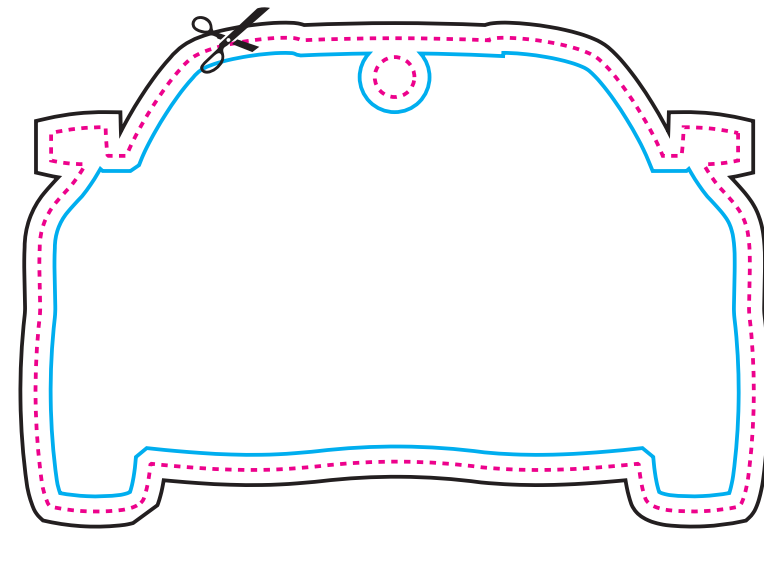

Fronte

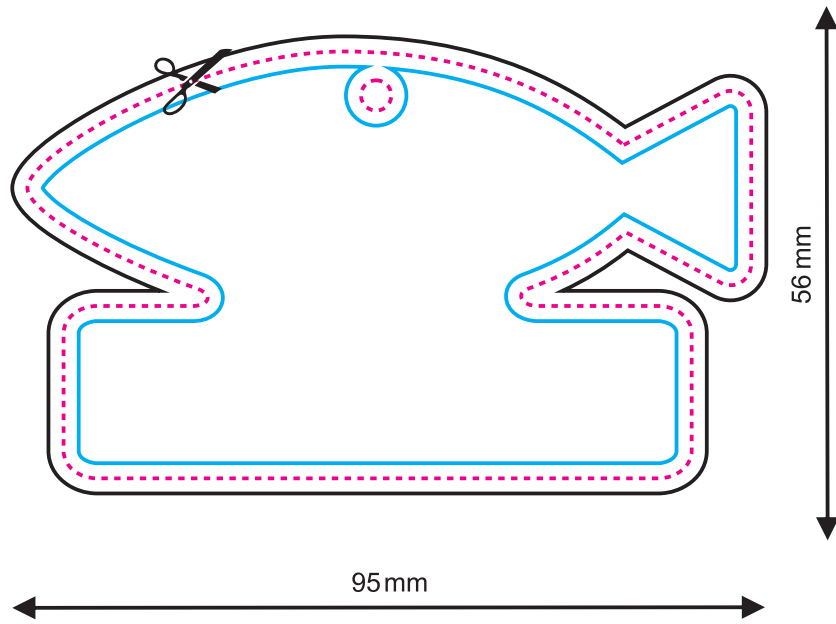

Retro

LINEA DEL TAGLIO PROGETTO CON ABBONDAGGIO LINEA DI SICUREZZA (tutti gli elementi importanti devono essere inseriti all'interno di questa linea) 

Fronte

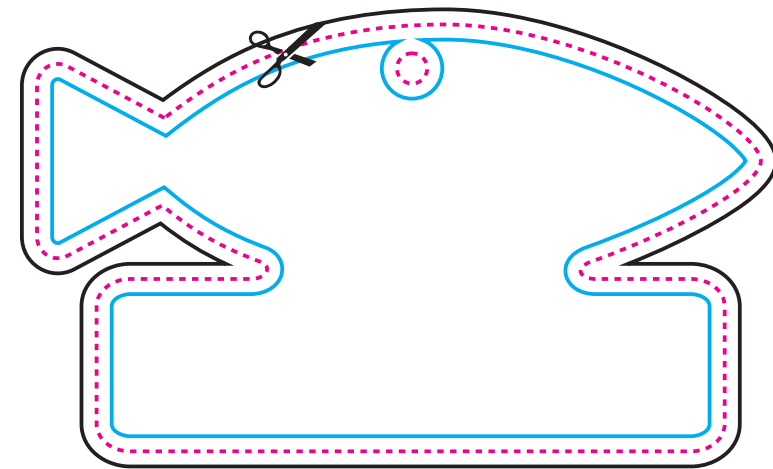

Retro

LINEA DEL TAGLIO



PROGETTO CON ABBONDAGGIO



LINEA DI SICUREZZA (tutti gli elementi importanti devono essere inseriti all'interno di questa linea)

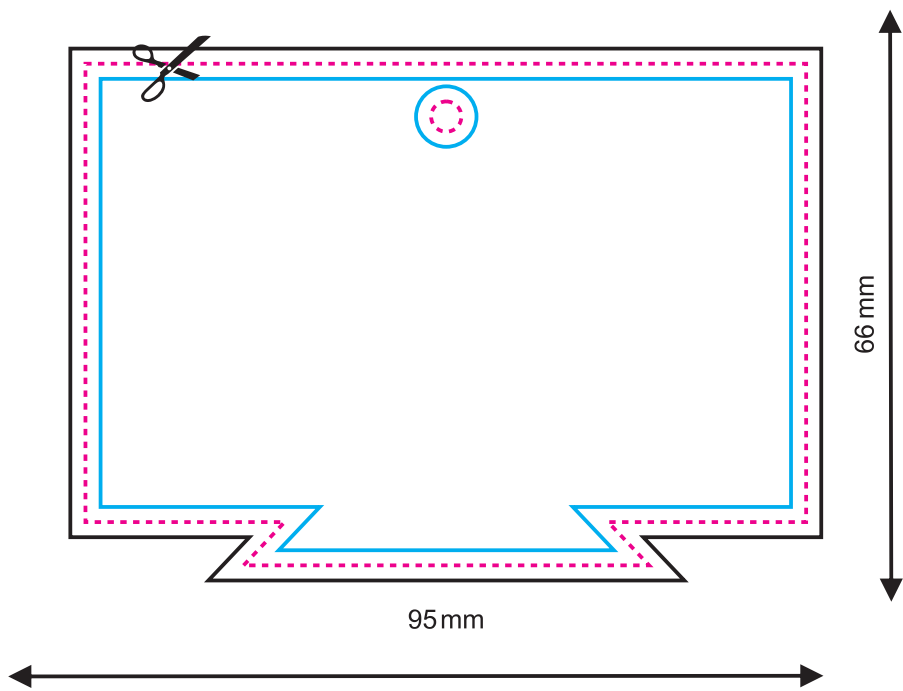
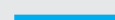

Fronte

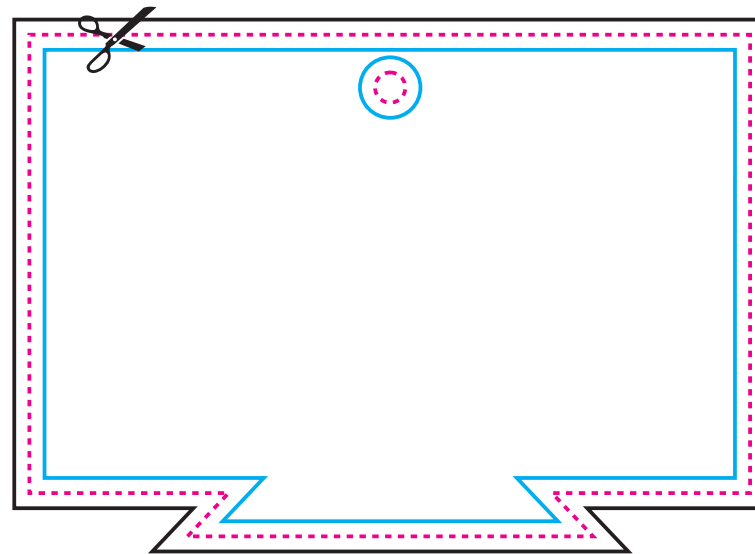

Retro

LINEA DEL TAGLIO



PROGETTO CON ABBONDAGGIO

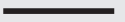

LINEA DI SICUREZZA (tutti gli elementi importanti devono essere inseriti all'interno di questa linea)

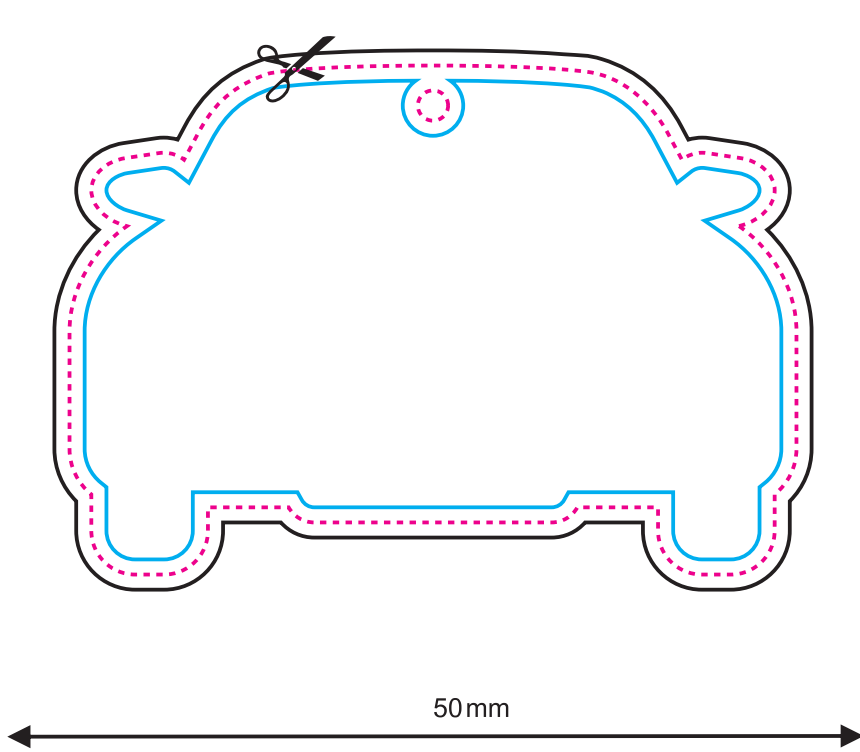
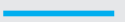

Fronte

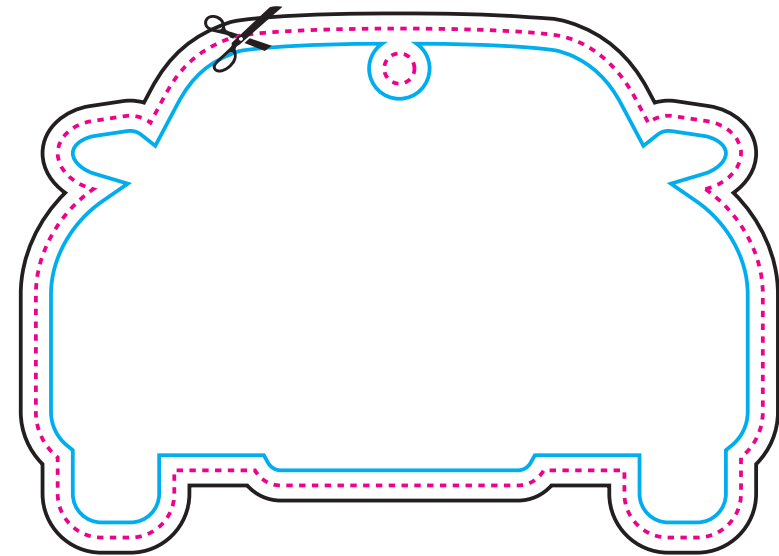

Retro

LINEA DEL TAGLIO



PROGETTO CON ABBONDAGGIO

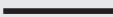

LINEA DI SICUREZZA (tutti gli elementi importanti devono essere inseriti all'interno di questa linea)

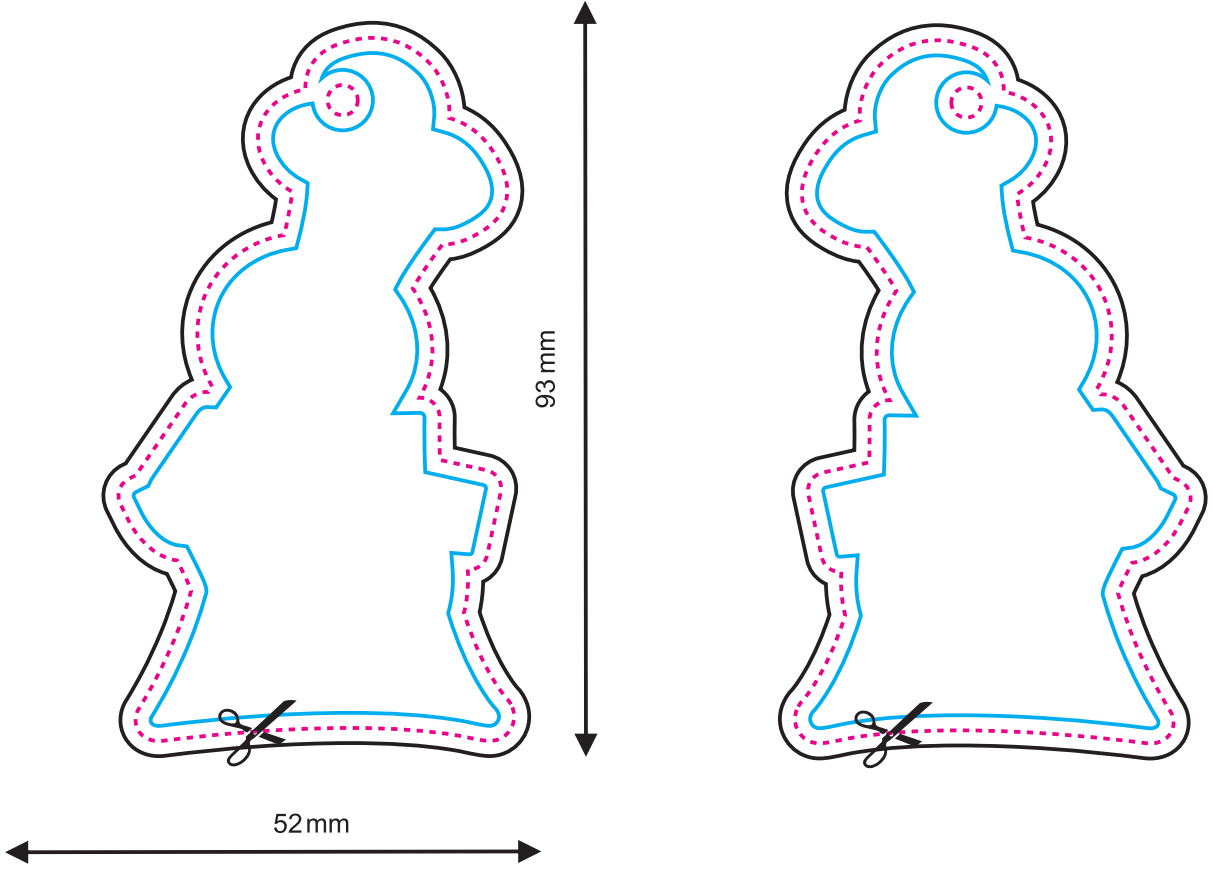

Fronte

Retro

LINEA DEL TAGLIO



PROGETTO CON ABBONDAGGIO

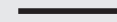

LINEA DI SICUREZZA (tutti gli elementi importanti devono essere inseriti all'interno di questa linea)

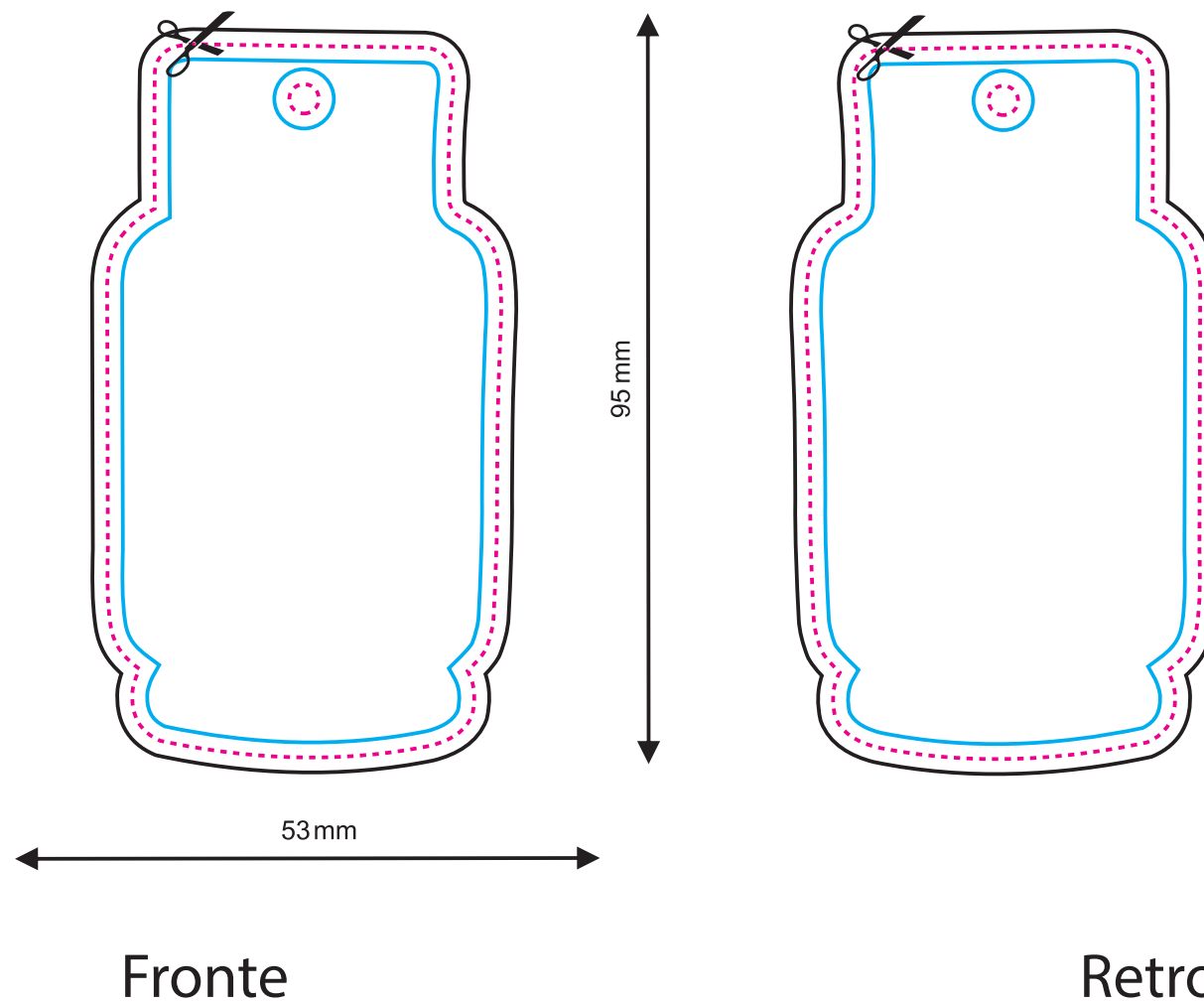
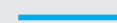

685

LEGENDA

LINEA DEL TAGLIO



PROGETTO CON ABBONDAGGIO

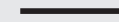

LINEA DI SICUREZZA (tutti gli elementi importanti devono essere inseriti all'interno di questa linea)

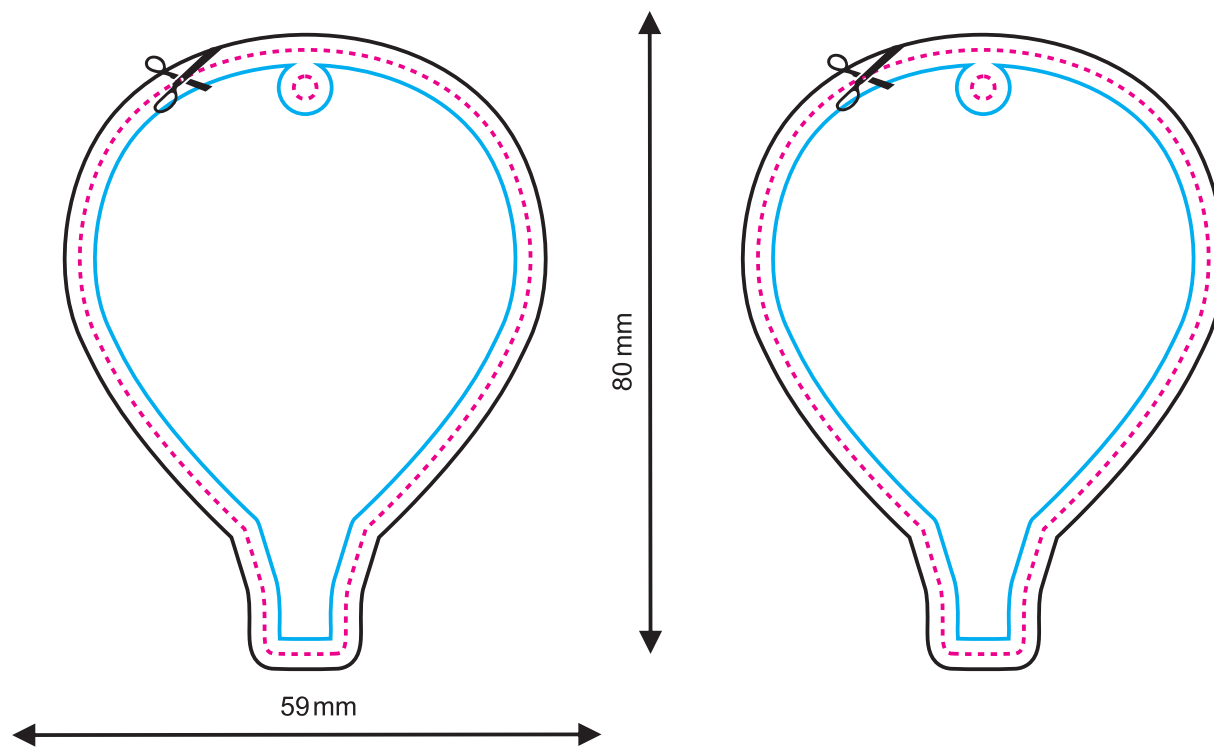
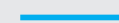

Fronte

Retro



LINEA DEL TAGLIO



PROGETTO CON ABBONDAGGIO

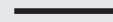

LINEA DI SICUREZZA (tutti gli elementi importanti devono essere inseriti all'interno di questa linea)

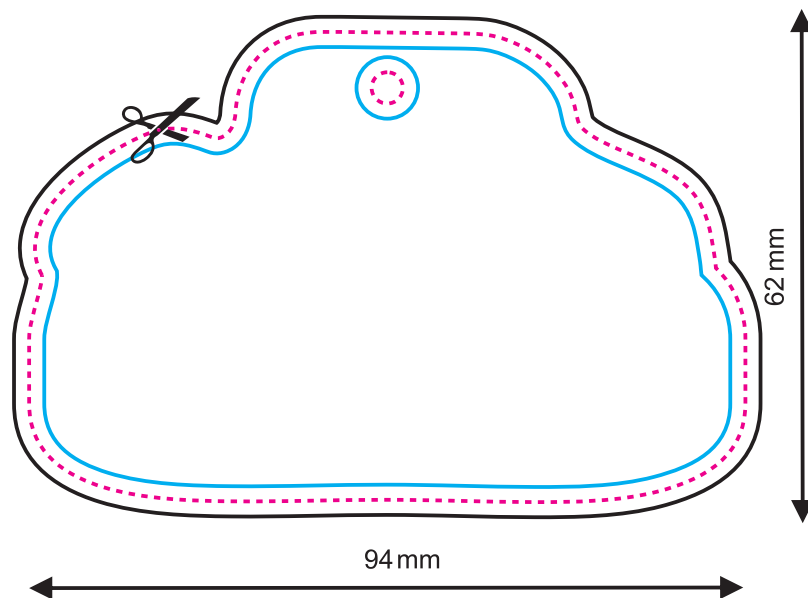
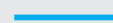

Fronte

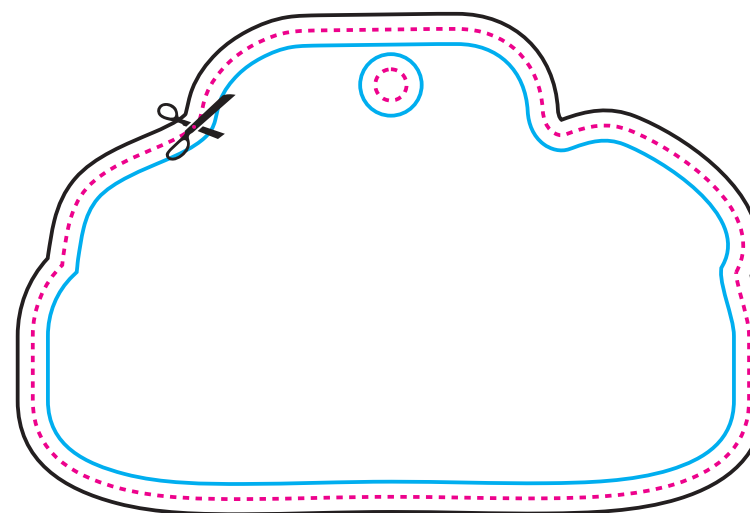

Retro

LINEA DEL TAGLIO



PROGETTO CON ABBONDAGGIO

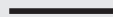

LINEA DI SICUREZZA (tutti gli elementi importanti devono essere inseriti all'interno di questa linea)

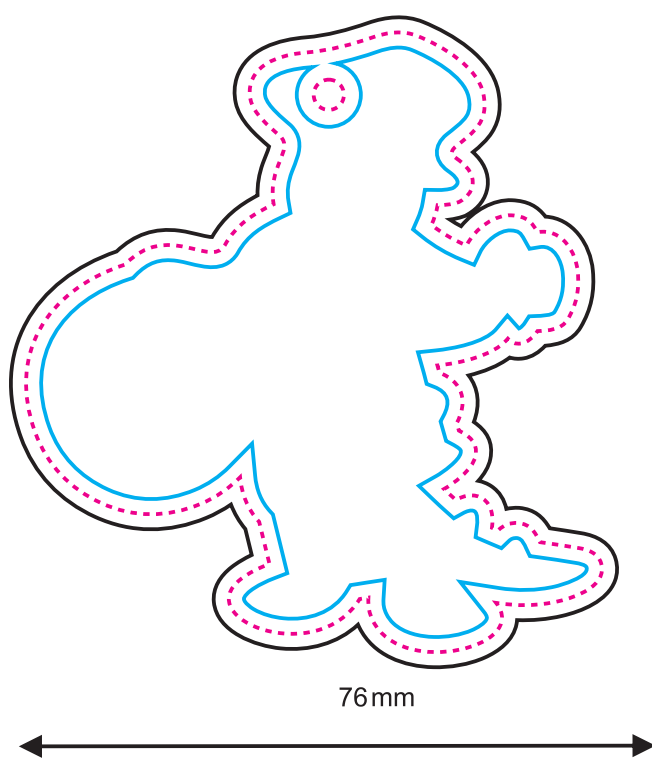

Fronte

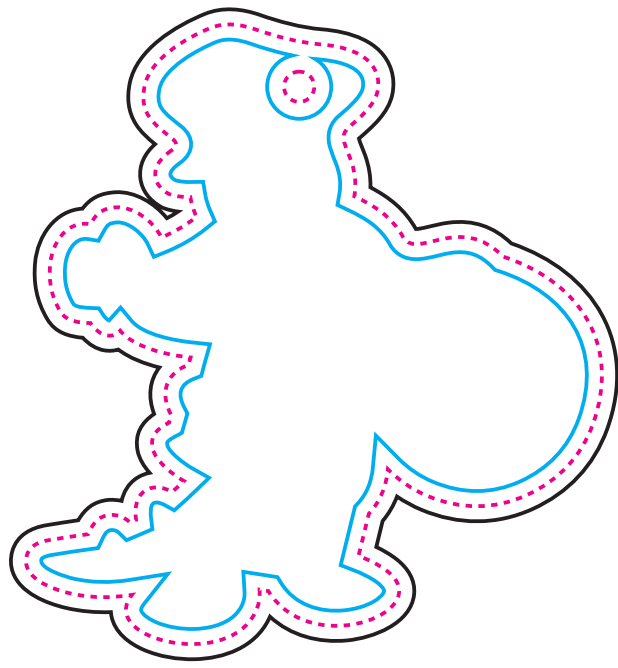

Retro

LINEA DEL TAGLIO



PROGETTO CON ABBONDAGGIO

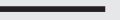

LINEA DI SICUREZZA (tutti gli elementi importanti devono essere inseriti all'interno di questa linea)

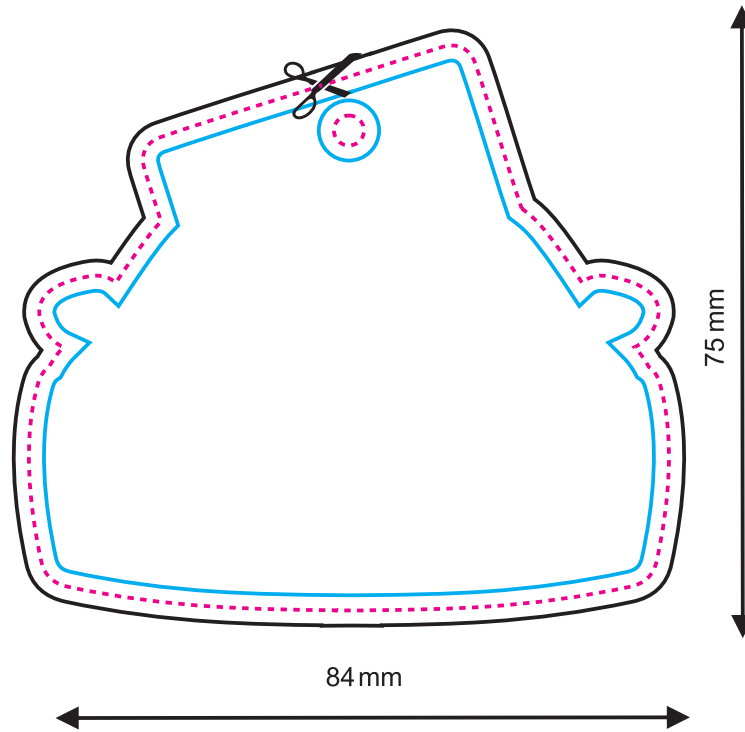

Fronte

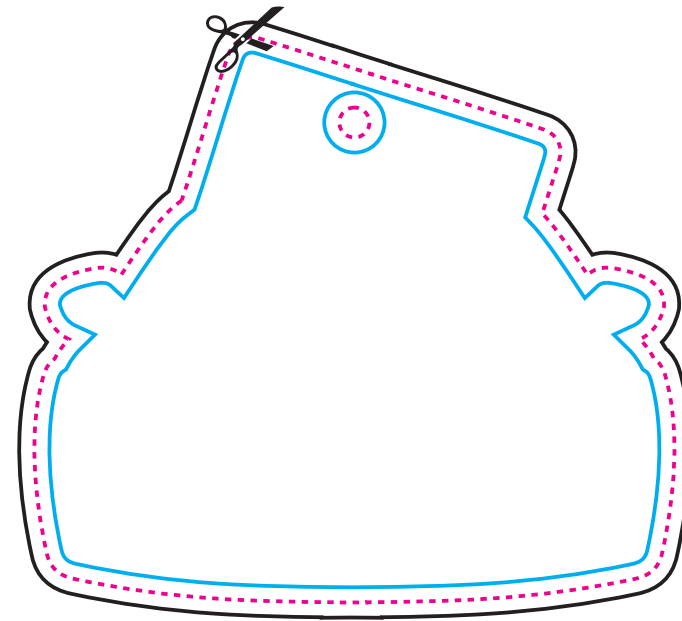

Retro

LINEA DEL TAGLIO



PROGETTO CON ABBONDAGGIO

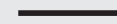

LINEA DI SICUREZZA (tutti gli elementi importanti devono essere inseriti all'interno di questa linea)

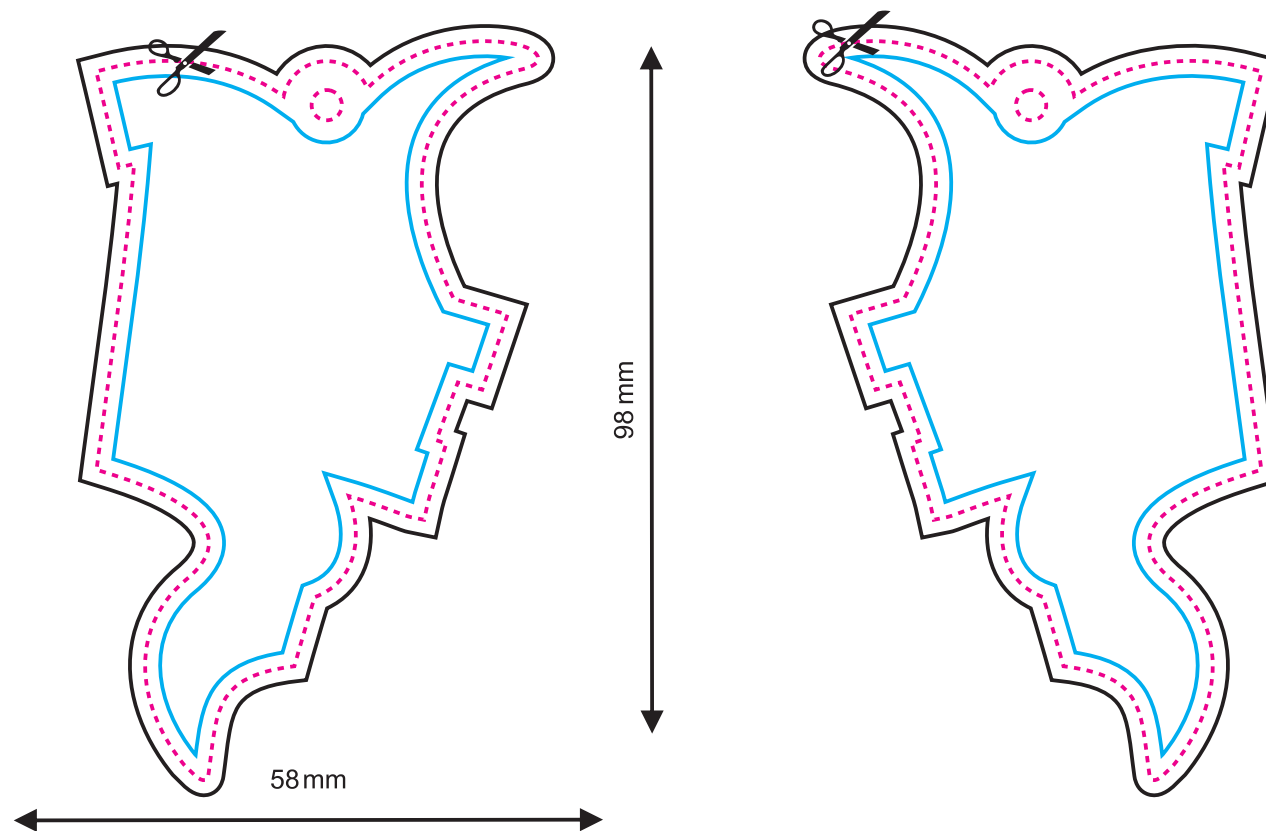
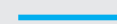

Fronte

Retro

LINEA DEL TAGLIO



PROGETTO CON ABBONDAGGIO

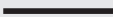

LINEA DI SICUREZZA (tutti gli elementi importanti devono essere inseriti all'interno di questa linea)

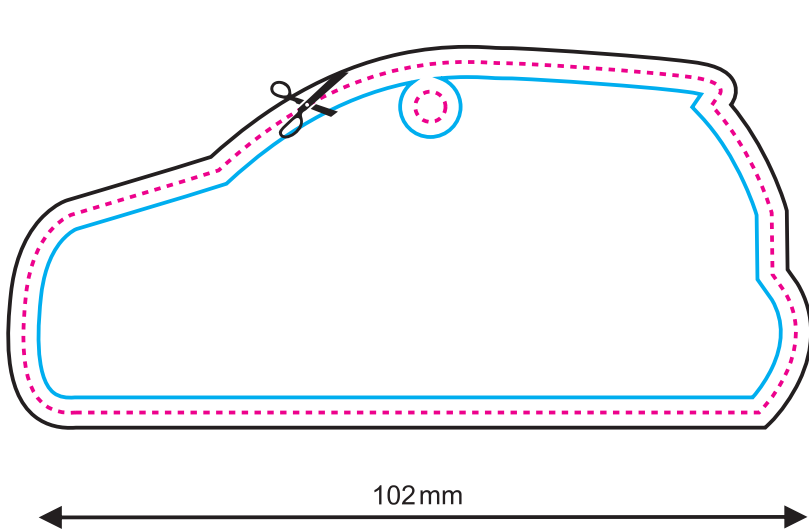

Fronte

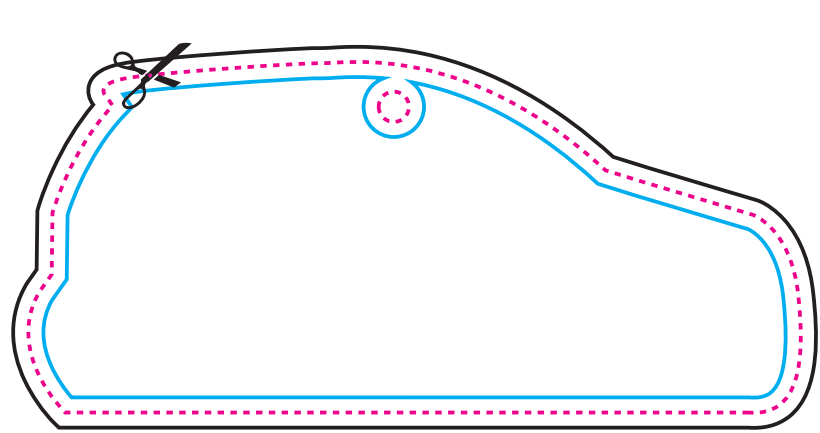

Retro

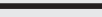
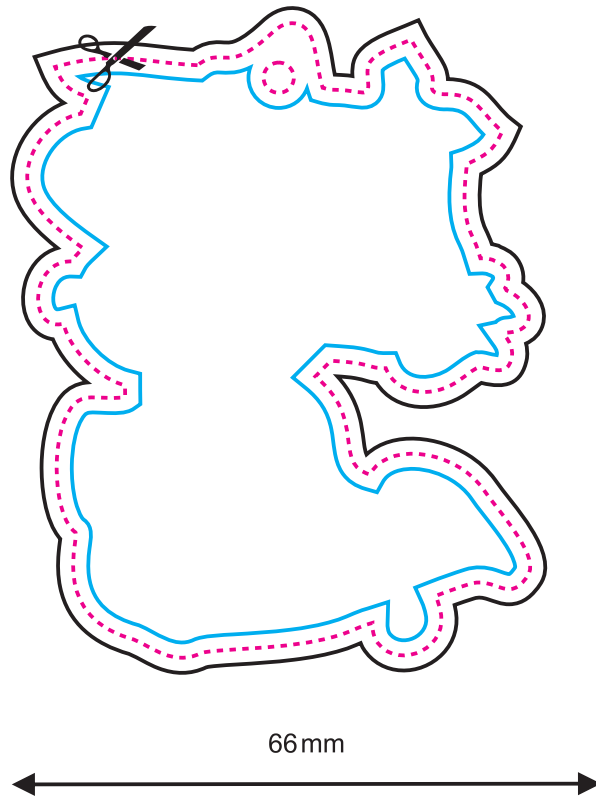
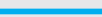
LINEA DEL TAGLIO PROGETTO CON ABBONDAGGIO LINEA DI SICUREZZA (tutti gli elementi importanti devono essere inseriti all'interno di questa linea) 

Fronte

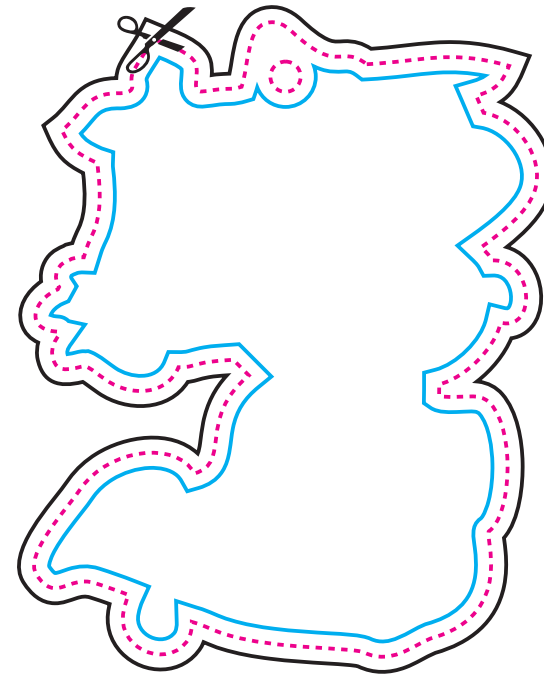

Retro

696

LEGENDA

LINEA DEL TAGLIO



PROGETTO CON ABBONDAGGIO

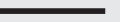

LINEA DI SICUREZZA (tutti gli elementi importanti devono essere inseriti all'interno di questa linea)

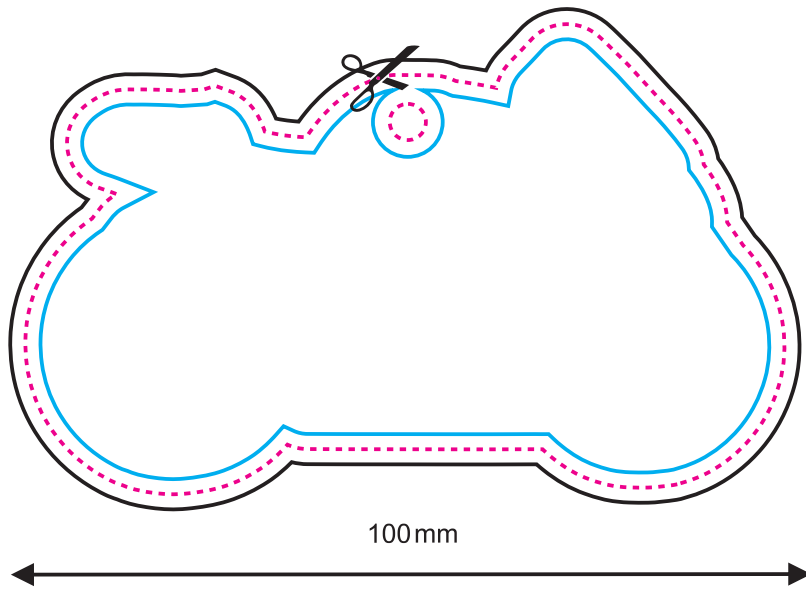
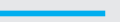

Fronte

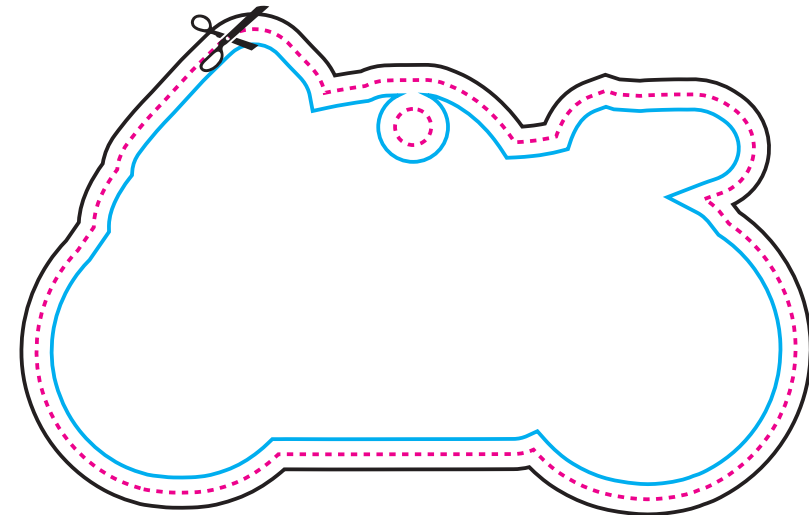

Retro

LINEA DEL TAGLIO



PROGETTO CON ABBONDAGGIO

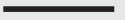

LINEA DI SICUREZZA (tutti gli elementi importanti devono essere inseriti all'interno di questa linea)

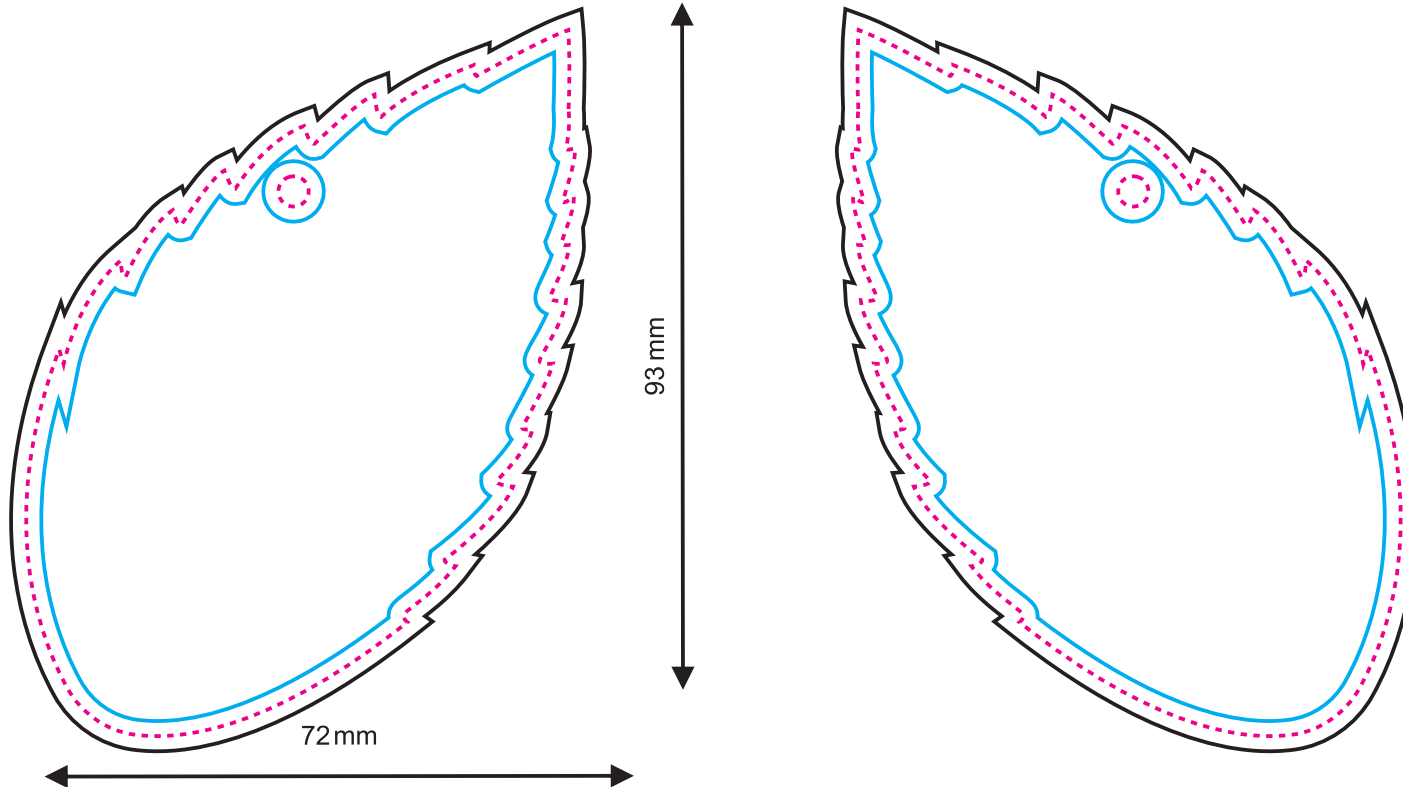
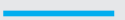

Fronte

Retro



LINEA DEL TAGLIO



PROGETTO CON ABBONDAGGIO

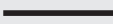

LINEA DI SICUREZZA (tutti gli elementi importanti devono essere inseriti all'interno di questa linea)

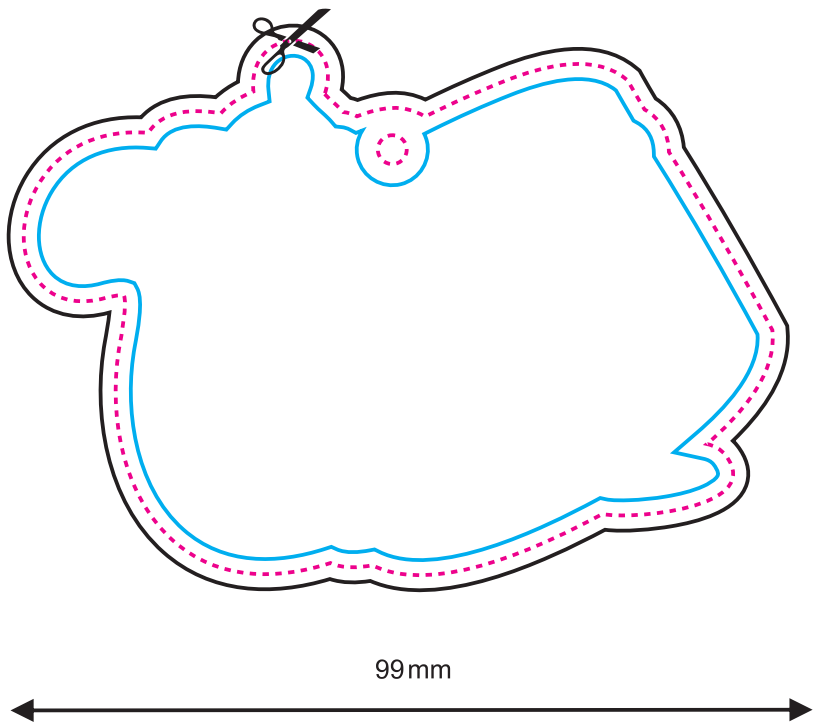

Fronte

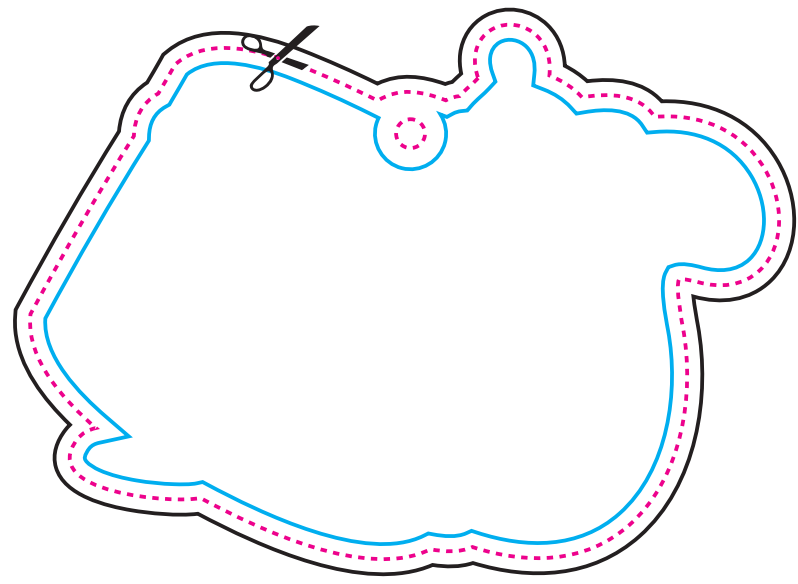

Retro

LINEA DEL TAGLIO



PROGETTO CON ABBONDAGGIO

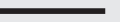

LINEA DI SICUREZZA (tutti gli elementi importanti devono essere inseriti all'interno di questa linea)

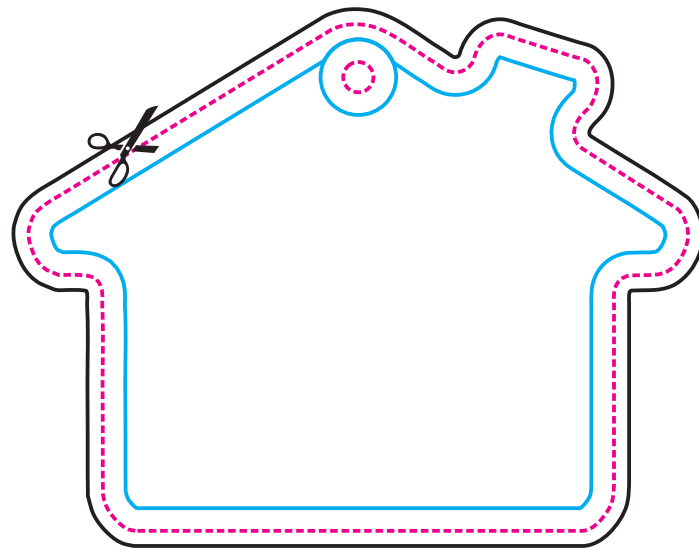
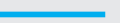

87mm



Fronte

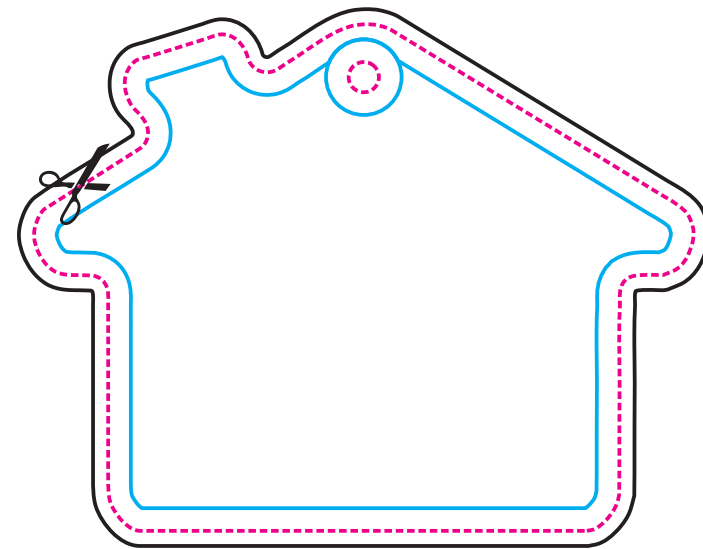

Retro

LINEA DEL TAGLIO



PROGETTO CON ABBONDAGGIO

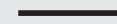

LINEA DI SICUREZZA (tutti gli elementi importanti devono essere inseriti all'interno di questa linea)

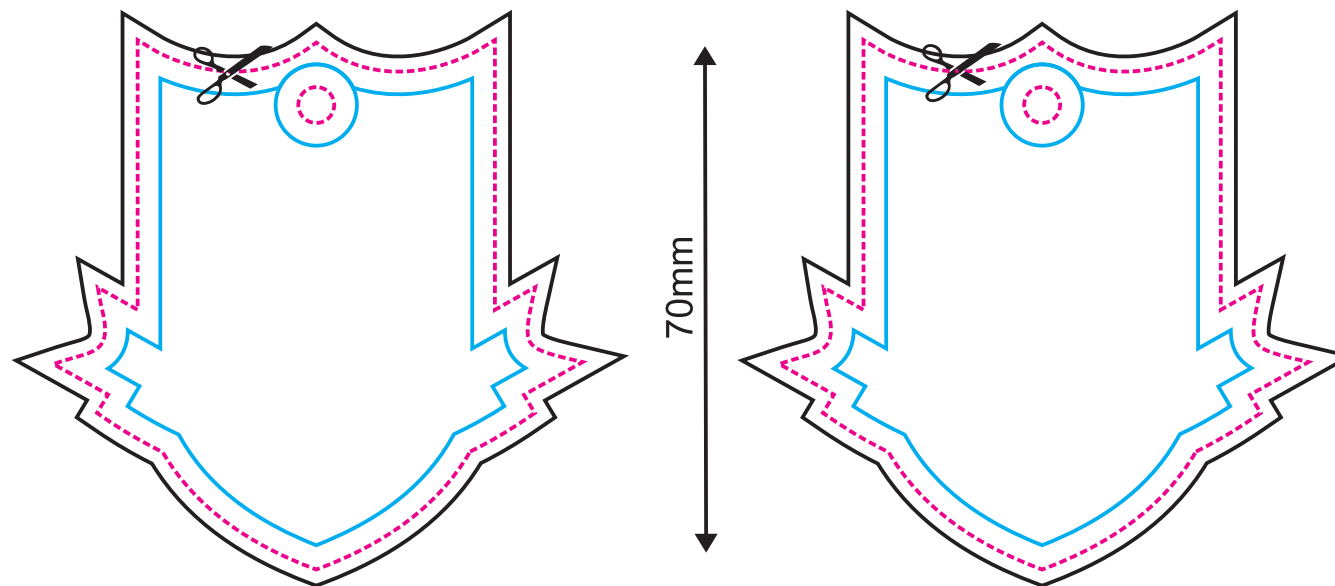
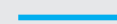

Fronte

Retro

LINEA DEL TAGLIO 

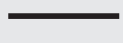
PROGETTO CON ABBONDAGGIO 

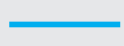
LINEA DI SICUREZZA (tutti gli elementi importanti devono essere inseriti all'interno di questa linea) 

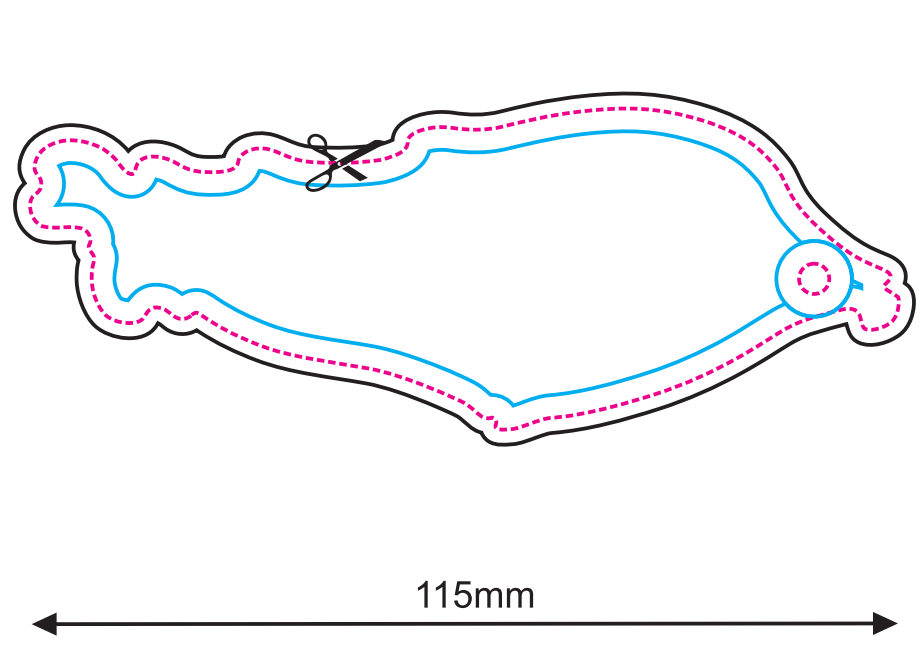

Fronte

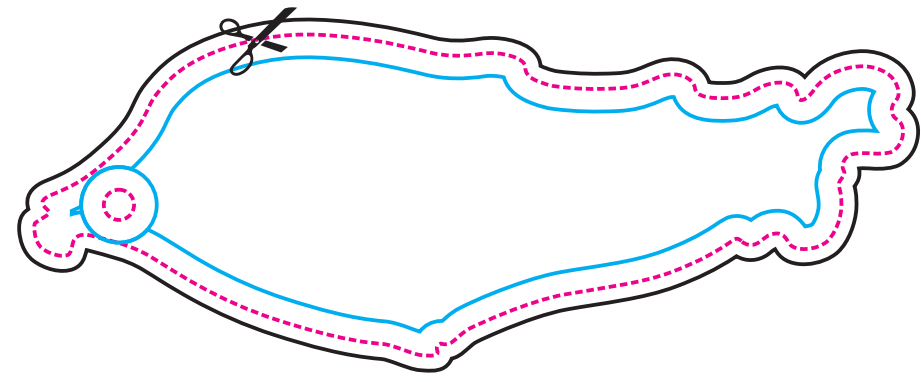

Retro